

LOC	DIST	REVISIONS			
P	LN	DESCRIPTION	DATE	BY	APP
GP	00	S	OBSOLETE -1,-2,-3 OS1D-0014-00	01NOV00	AH JR

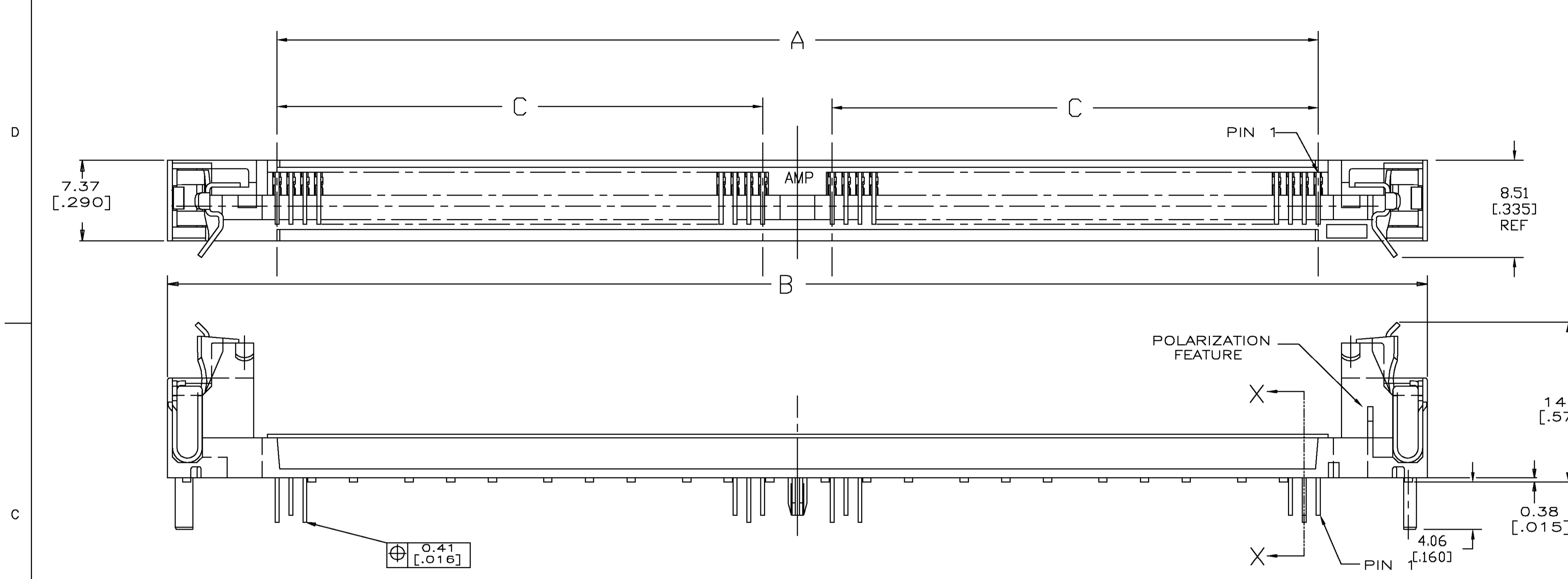

- △ HOUSING-MATERIAL : LIQUID-CRYSTAL-POLYMER, COLOR: NATURAL.
- △ CONTACT-MATERIAL : PHOS. BRONZE.
- △ LATCH-MATERIAL : BRASS, NICKEL PLATE
- △ CONTACT-PLATE: 0.00508[.000200] MIN. TIN/LEAD OVER 0.00127 [.000050] MIN NICKEL.
- 5. IN ADDITION TO THOSE RECOMMENDED "SIMM" P.C. BOARD DIMENSIONS AND TOLERANCES SHOWN, ALL JEDEC SPECIFICATIONS APPLY AS SHOWN ON MO-116, ISSUE A.
- 6. RECOMMENDED MATING S.I.M.M. TAB METALLURGY: BASE METAL-COPPER. PLATING TO BE 0.00762[.000300] MIN TIN/LEAD OVER 0.00127[.000050] MIN NICKEL.
- △ OBSOLETE

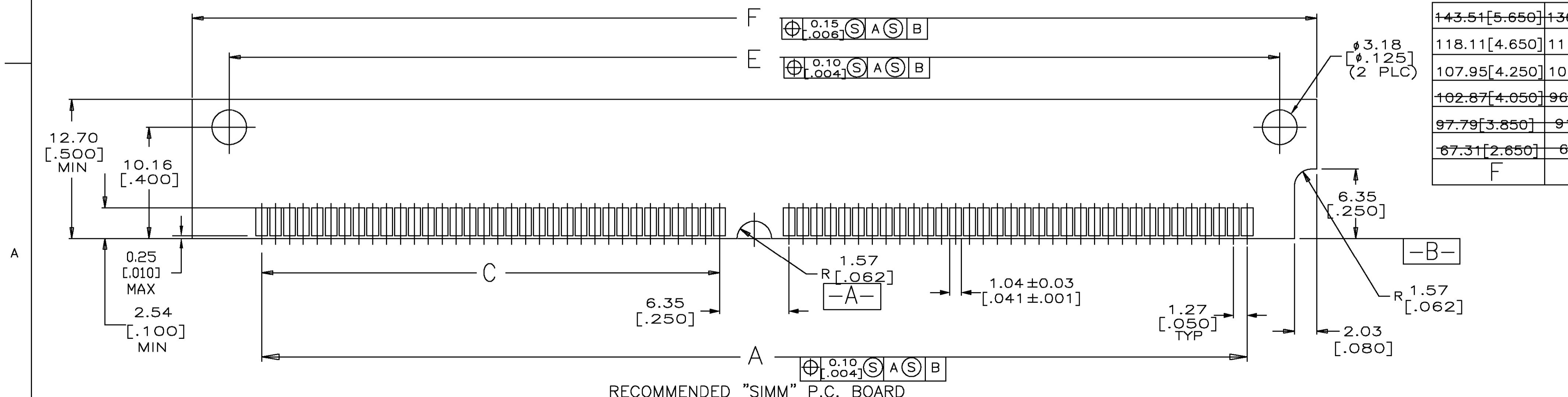
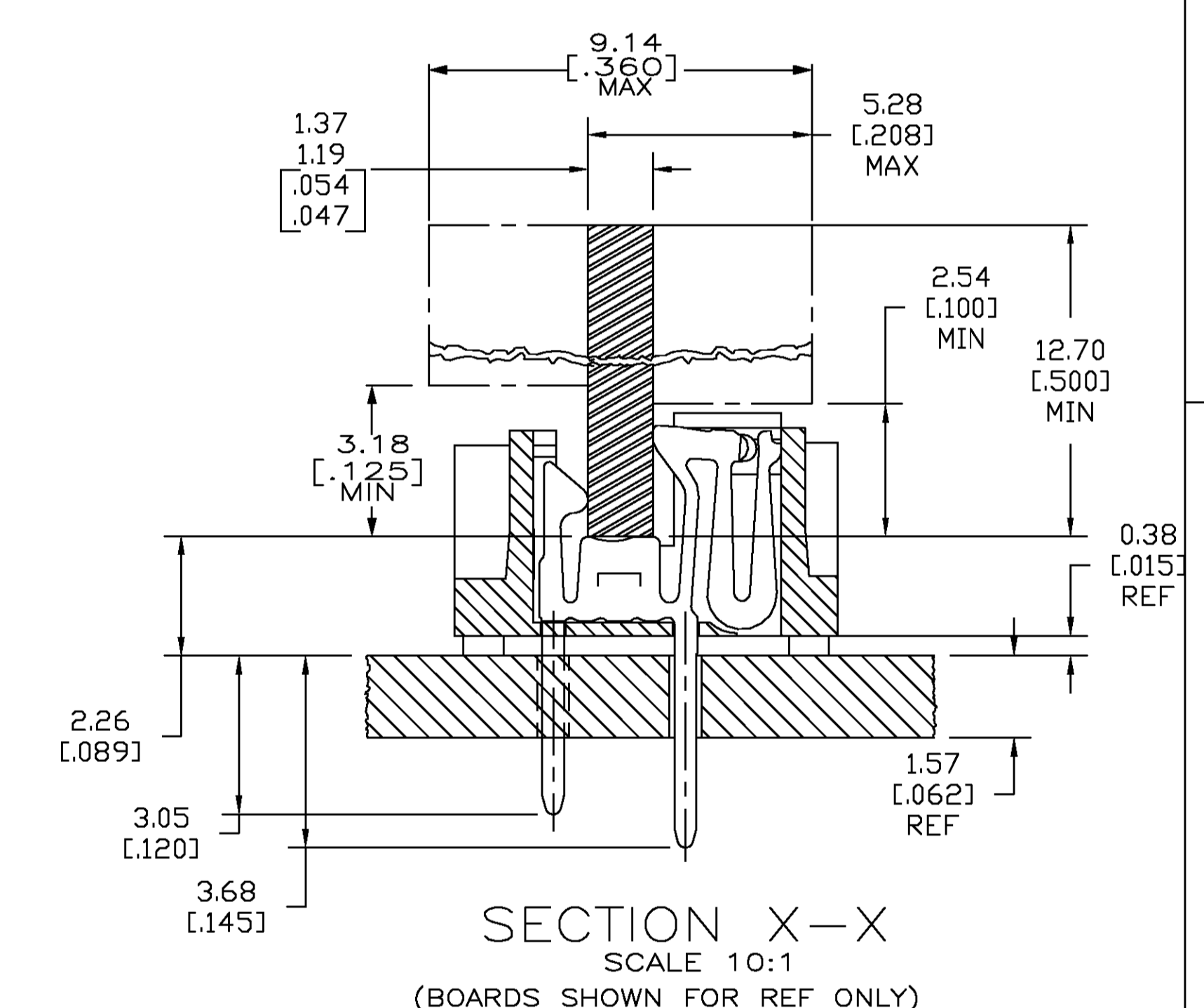
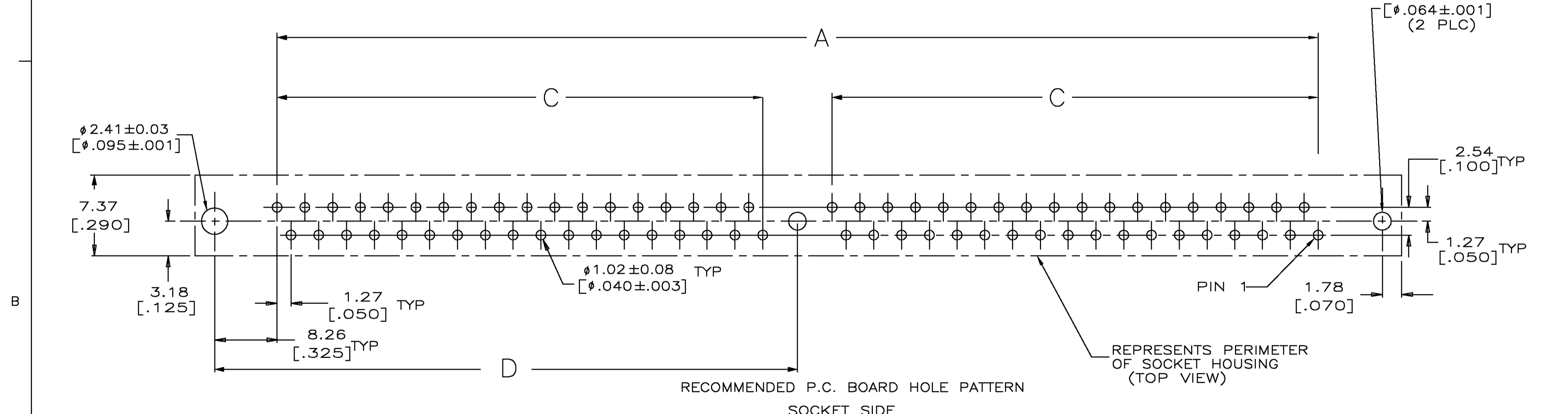

143.51[5.650]	136.75[5.384]	73.66[2.900]	62.23[2.450]	151.13[5.950]	130.81[5.150]	100	△ 822021-6
118.11[4.650]	111.35[4.384]	60.96[2.400]	49.53[1.950]	125.73[4.950]	105.41[4.150]	80	822021-5
107.95[4.250]	101.19[3.984]	55.88[2.200]	44.45[1.750]	115.57[4.550]	95.25[3.750]	72	822021-4
102.87[4.050]	96.11[3.784]	53.34[2.100]	41.91[1.650]	110.49[4.350]	90.17[3.550]	68	△ 822021-3
97.79[3.850]	91.03[3.584]	50.80[2.000]	39.37[1.550]	105.41[4.150]	85.09[3.350]	64	△ 822021-2
67.31[2.650]	60.55[2.384]	35.56[1.400]	24.13[.950]	74.93[2.950]	54.61[2.150]	40	△ 822021-1
F	E	D	C	B	A	NO OF POSN	PART NO

THIS DRAWING IS A CONTROLLED DOCUMENT.

DIM: K. SALMON 3-21-91	AMP Incorporated Harrisburg PA 17105-3608
CHK: R. MILLER 3-25-91	CONNECTOR, MICRO-EDGE, .050, VERT, TIN PL, W/METAL LATCH
APP: J. LAMBERT 3-26-91	SIZE: A1
PRODUCT SPEC: ---	DATE CODE: 00779
APPLICATION SPEC: ---	DRAWING NO: C-822021
WEIGHT: ---	SCALE: 4:1
CUSTOMER DRAWING	SHEET 1 OF 1