

- NOTE) 1 . ALL LEAD CO-PLANARITY SHALL BE 0.08mm MAX
 2 CONTACT PLATING SPECIFICATIONS.
 CONTACT AREA : GOLD 0.05 μm MIN
 SMT LEAD : GOLD 0.05 μm MIN
 UNDERPLATING : NICKEL 1 μm MIN
 (SURFACE : SEALING)
 3 HRS MARK AND CAV NO. ARE INDICATED IN APPROX POSITION SHOWN.
 4 GATE POSITION IS INDICATED IN APPROX POSITION SHOWN.

A-A (50:1)

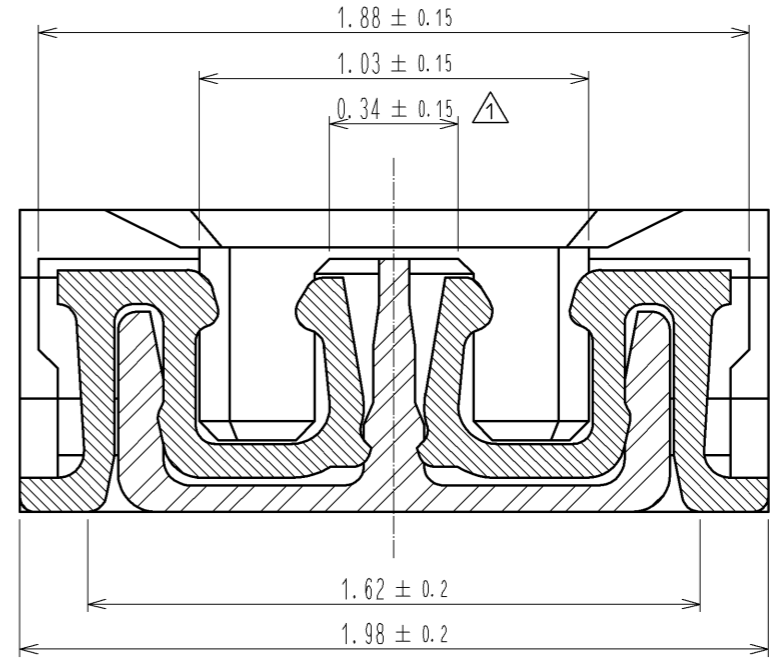

ENGAGEMENT FIGURE (50:1)

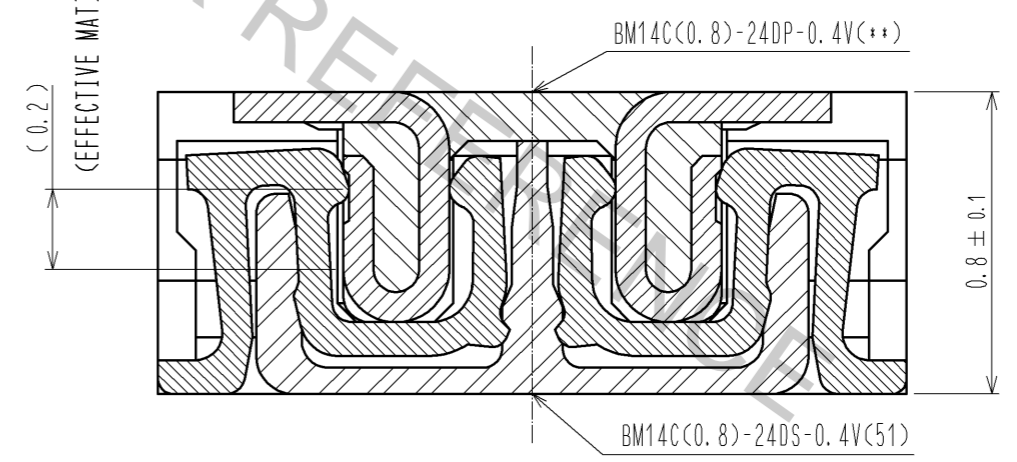

3	PS	CLEAR (ENBOSSED CARRIER TAPE)	6	PS	CLEAR (REINFORCEMENT COLLAR)		
2	PHOSPHOR BRONZE	2	5	PS	BLACK (PLASTIC REEL)		
1	LCP	UL94 V-0, BLACK	4	POLYESTER	CLEAR (COVER TAPE)		
NO.	MATERIAL	FINISH, REMARKS	NO.	MATERIAL	FINISH, REMARKS		
UNITS mm		SCALE 10:1	COUNT 3	DESCRIPTION OF REVISIONS DIS-H-005556	DESIGNED YN. SAKAMOTO	CHECKED TS. MIYAZAKI	DATE 11.02.25
HRS HIROSE ELECTRIC CO., LTD.		APPROVED : KH. IKEDA 09.08.28	DRAWING NO. EDC3-324407-01				
		CHECKED : WR. FUKUCHI 09.08.28	PART NO. BM14C(0.8)-24DS-0.4V(51)				
		DESIGNED : TY. OOI 09.08.28	CODE NO. CL684-8018-2-51				
		DRAWN : YN. SAKAMOTO 10.12.24					

◆ RECOMMENDED PCB LAYOUT

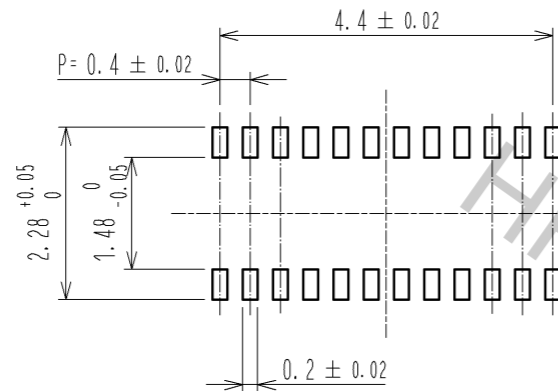

◆ RECOMMENDED METAL MASK DIMENSIONS

METAL MASK THICKNESS : 100 μ m

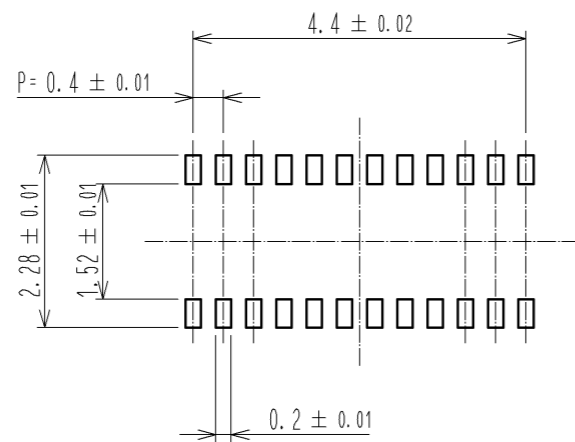

5 RECOMMENDED REFLOW TEMPERATURE PROFILE USING LEAD-FREE SOLDER PASTE.

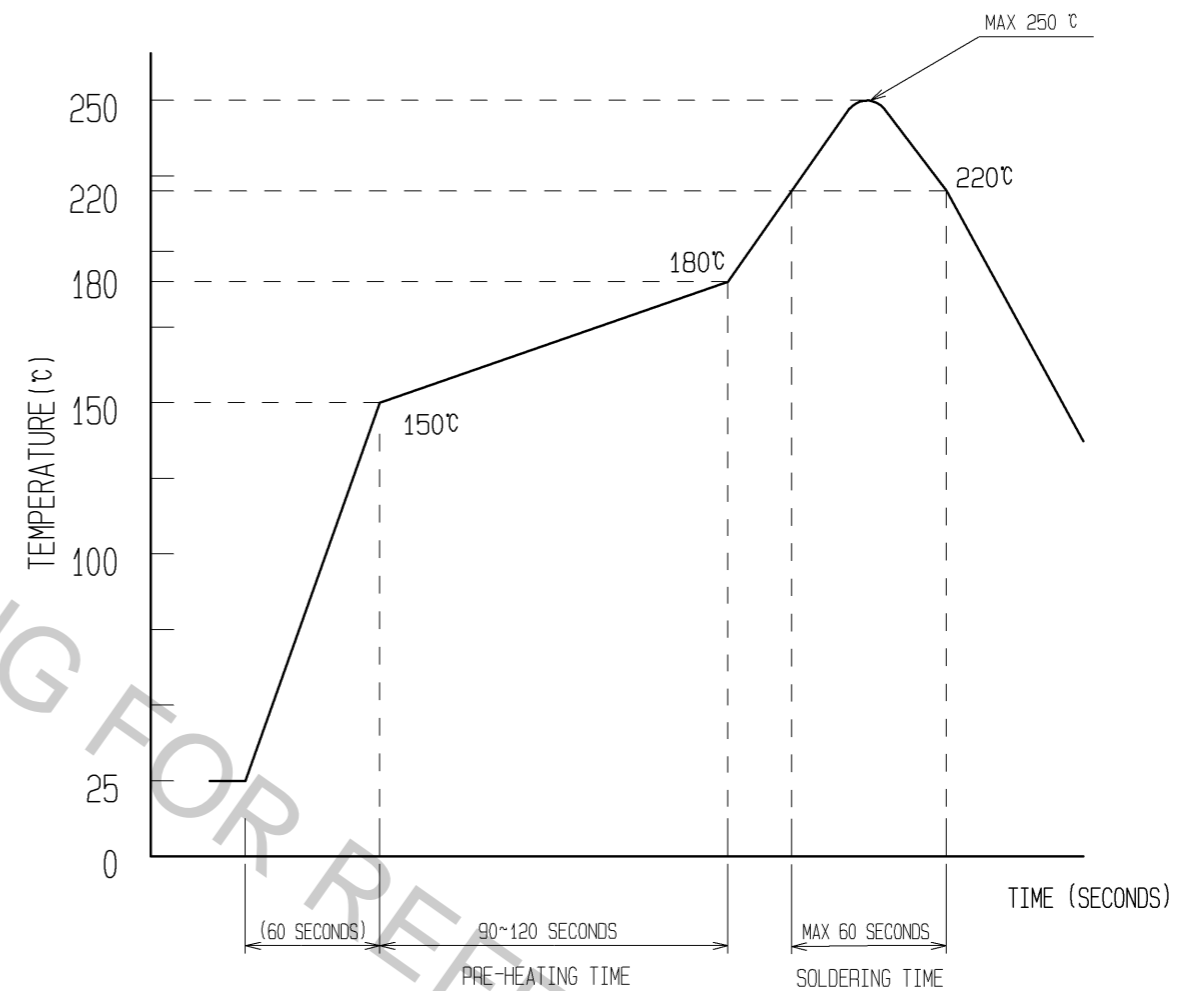

- REFLOW METHOD: IR REFLOW.
 NUMBER OF REFLOW CYCLES: 2 CYCLES MAX.
 1) REFLOW TIME
 DURATION ABOVE 220°C, 60 SEC. MAX.
 (PEAK TEMPERATURE: 250°C MAX)
 2) PRE-HEAT TIME
 PRE-HEAT TEMPERATURE(MIN): 150°C
 PRE-HEAT TEMPERATURE(MAX): 180°C
 PRE-HEAT TIME: 90-120 sec.

5 THIS TEMPERATURE PROFILE IS PER THE CONDITIONS SHOWN ABOVE. ADDITIONAL FACTORS, SUCH AS SOLDER PASTE TYPE, PCB SIZE AND OTHER MOUNTED COMPONENTS COULD AFFECT THE PROFILE, THEREFORE, A THOROUGH EVALUATION OF MOUNTING CONDITION IS REQUIRED PRIOR TO PRODUCTION. TEMPERATURE IS MEASURED AT CONTACT LEAD.

HRS	DRAWING NO.	EDC3-324407-01
	PART NO.	BM14C(0.8)-24DS-0.4V(51)
	CODE NO.	CL684-8018-2-51

EMBOSSED CARRIER TAPE PACKAGING (5:1)

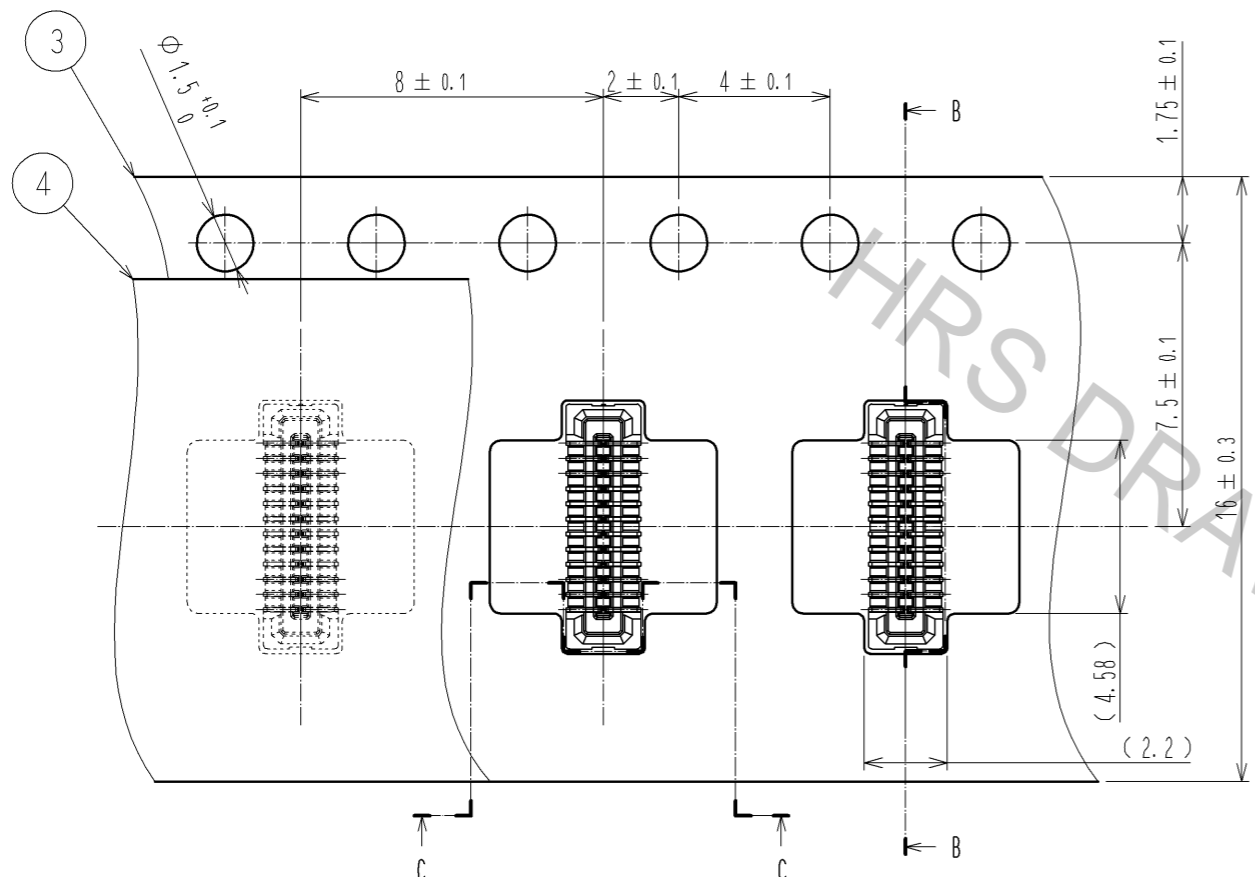

DIRECTION OF UNREELING

C-C (5:1)

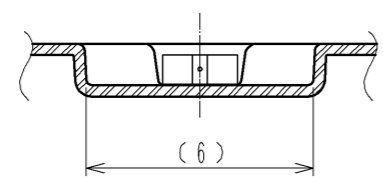

B-B (5:1)

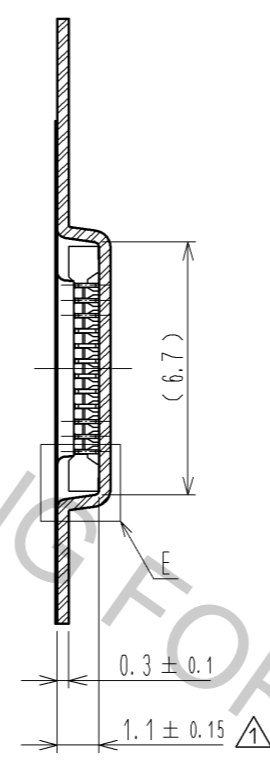

E(10:1)

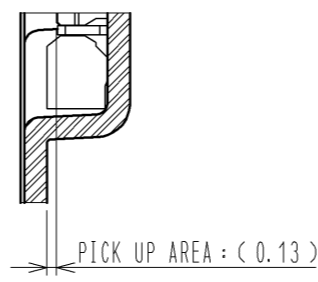

STYLE AND DIMENTION OF REEL (FREE)

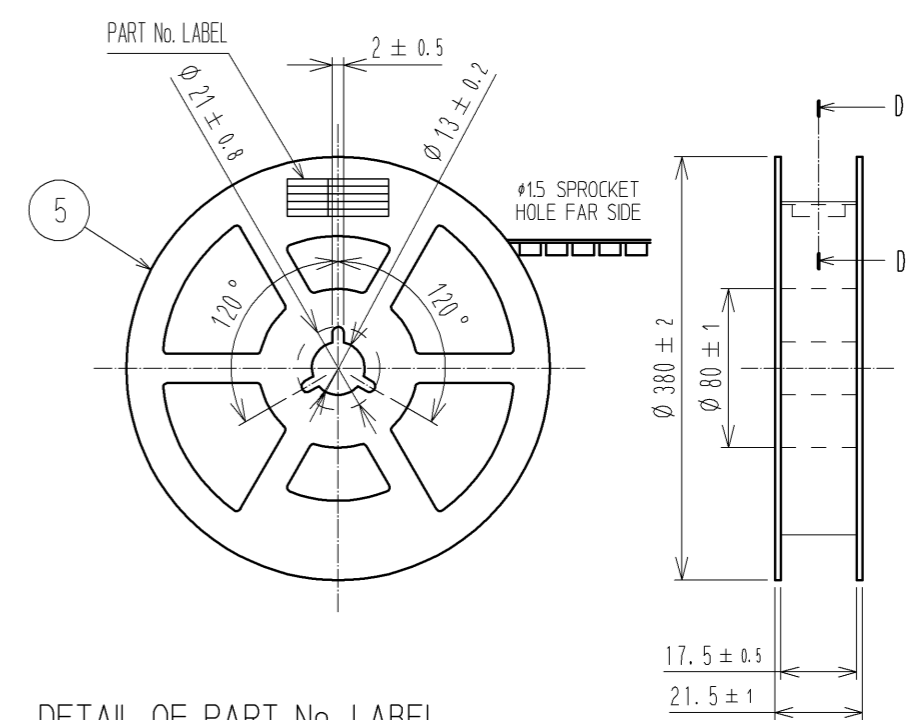

DETAIL OF PART No. LABEL

製造年月日	** ** *	DATE OF MANUFACTURED
製品コード	CL0684-8018-2-51	CODE No.
製品名	BM14C(0.8)-24DS-0.4V(51)	PART No.
数量	8,000	QUANTITY
納入者	ヒロセ電機(株)	SUPPLIER

DATE OF MANUFACTURED
 CODE No.
 PART No.
 QUANTITY
 SUPPLIER

D-D (FREE)

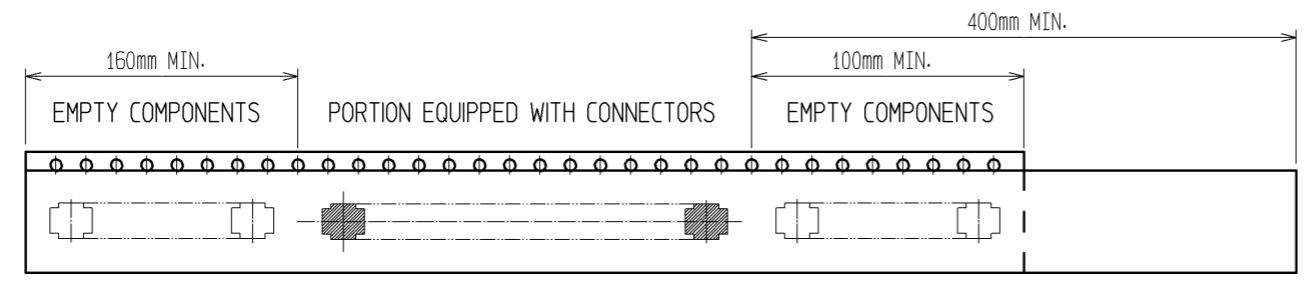
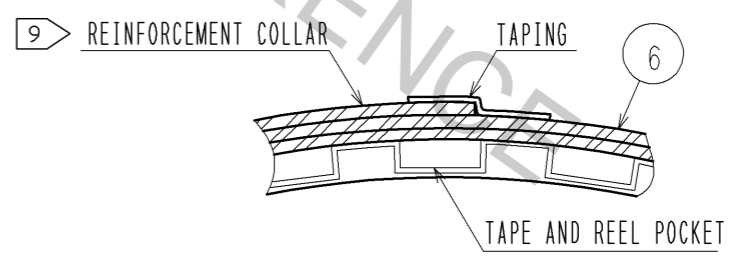

TRAILER 8 TAPING (FREE) LEADER

- 6. PER REEL 8000 CONNECTORS.
- 7. THE DIMENSIONS IN PARENTHESES ARE FOR REFERENCE.
- 8 REFER TO JIS C 0806(PACKAGING OF COMPONENTS FOR AUTOMATIC HANDLING)
- 9 AFTER PACKAGING, ROLL 2 METERS OF THE REINFORCEMENT COLLAR TO OUTER CIRCUMFERENCE OF TAPE AND REEL POCKET, AND TAPE DOWN AT THE END THE COLLAR.

HRS	DRAWING NO.	EDC3-324407-01
	PART NO.	BM14C(0.8)-24DS-0.4V(51)
	CODE NO.	CL684-8018-2-51
		$\triangle 1$ 3/3