

THIS COPY IS PROVIDED ON A RESTRICTED BASIS AND IS NOT TO BE USED IN ANY WAY DETRIMENTAL TO THE INTERESTS OF PANDUIT CORP.

PART NUMBER	MATERIAL	"A" HEIGHT	IMPRINT AREA "B"	"C" REPEAT	LABELS PER ROW	ROWS PER FANFOLD	STANDARD PKG. QTY.
S050X125VAD	GMV3	1.250 [31.8]	0.38 +/- .031 [9.53]	1.50 [38.1]	16	8	5000
S050X150VAD	GMV3	1.500 [38.1]	0.50 +/- .031 [12.7]	2.00 [50.8]	16	6	5000
S050X125TAD	GMT1	1.250 [31.8]	0.38 +/- .031 [9.53]	1.50 [38.1]	16	8	5000
S050X150TAD	GMT1	1.500 [38.1]	0.50 +/- .031 [12.7]	2.00 [50.8]	16	6	5000
S050X125VADY	GMV3	1.250 [31.8]	0.38 +/- .031 [9.53]	1.50 [38.1]	16	8	5000
S050X150VADY	GMV3	1.500 [38.1]	0.50 +/- .031 [12.7]	2.00 [50.8]	16	6	5000

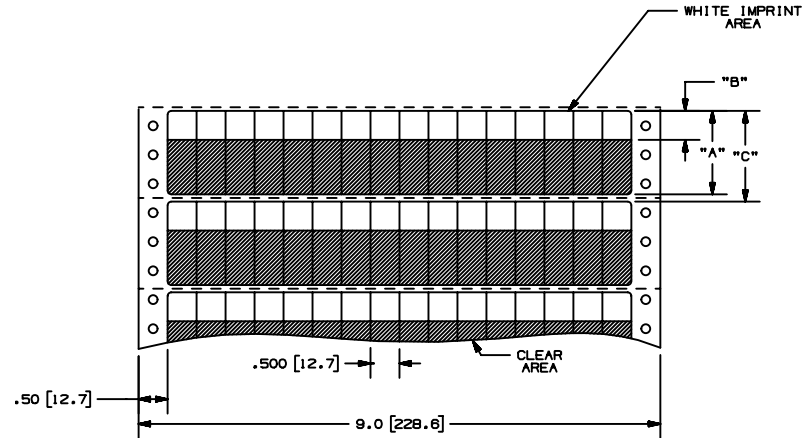

- NOTES:
 1. ALL LABELS TO BE BUTT-CUT AS SHOWN.
 2. MILLIMETERS ARE IN [].
 3. SEE MFG. DWG. A61149.

CAD FILENAME/LAYERS									
I00472LN_C10378_S050XxxxVADTAD_00.prt									
PANDUIT CORP TINLEY PARK, ILLINOIS									
CUSTOMER DRAWING OPTIMUM SELF-LAM. S050X***VAD, S050X***VADY, AND S050X***TAD COMPUTER PRINTABLE LABELS									
UNLESS OTHERWISE SPECIFIED, DIMENSIONAL TOLERANCES ARE: (.X) ± .031 (.XXX) ± .005 (.XX) ± .015 ANGLES ± 1°					UNLESS OTHERWISE SPECIFIED, ALL DIMENSIONS ARE GIVEN IN INCHES, THIRD ANGLE PROJECTION				
DRAWN BY RVU		MATERIAL		SCALE NTS		DRAWING NO. C10378		DWG SIZE B	
DATE 9-7-05		SEE TABLE							
REV 0		DATE 9-7-05		BY RVU		CHK		DESCRIPTION RELEASED TO PRODUCTION.	
REV		DATE		BY		CHK		DESCRIPTION	
								ECN - R CUST SUP	