

PART NUMBER	REV	FIRST USED
680695-1	A	122500-1
680695-2	A	565435-5
680695-3	A	354500-1

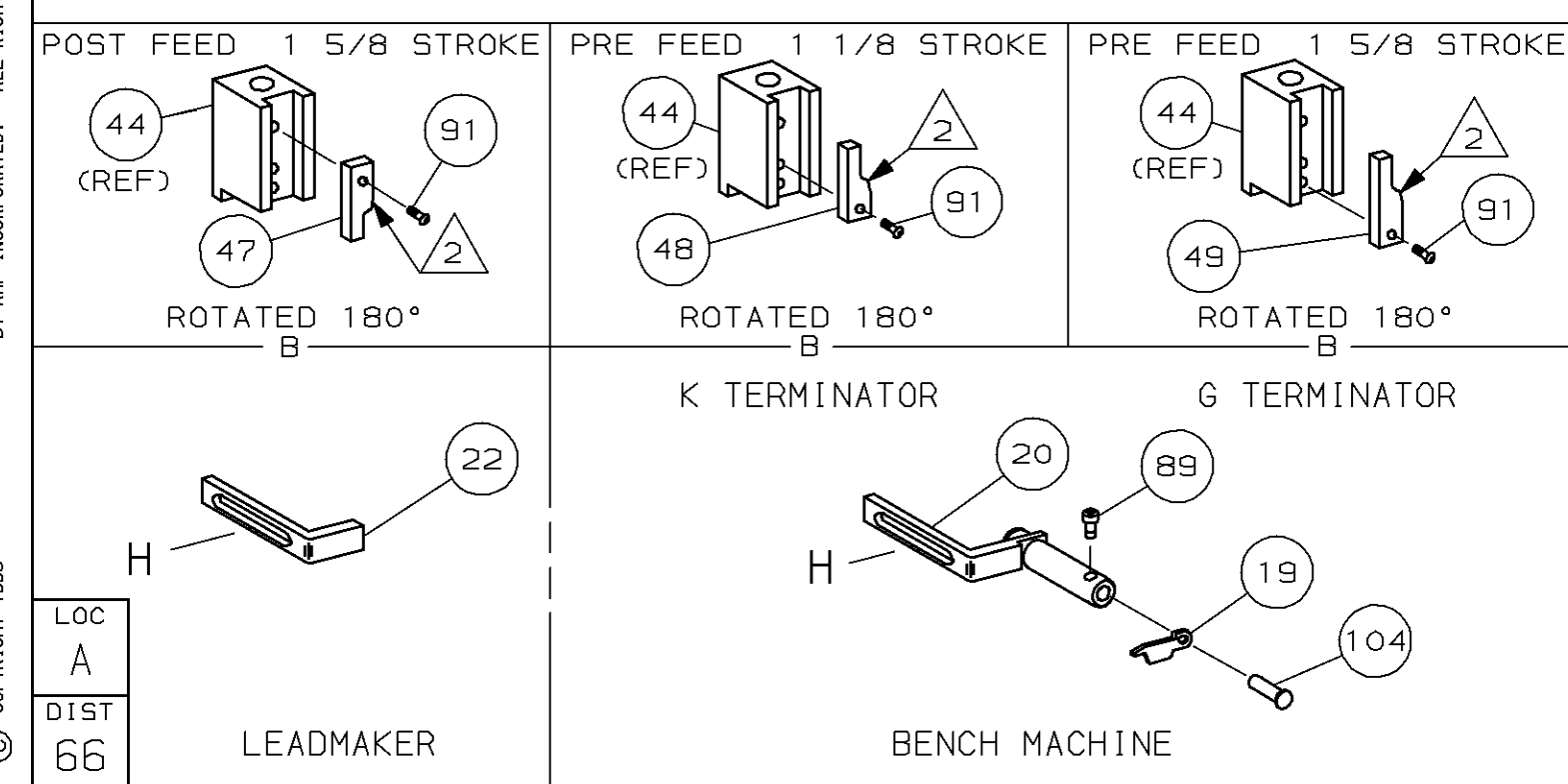
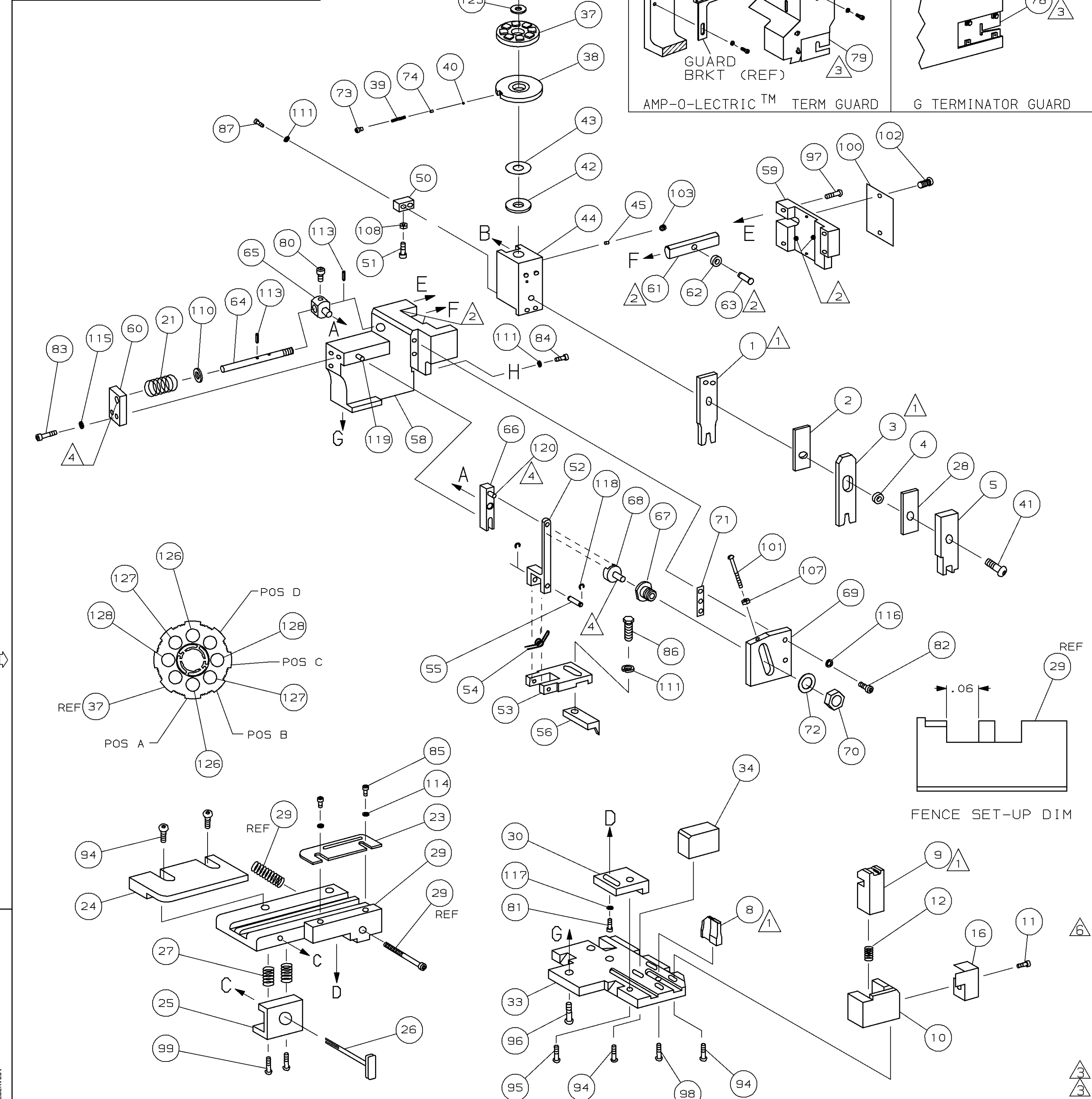

- 1 RECOMMENDED SPARE PARTS.
- 2 GREASE LIGHTLY.
- 3 GUARD MUST BE IN PLACE WHEN OPERATING APPLICATOR IN A BENCH MACHINE.
- 4 LUBRICATE DAILY USING NO. 20 MACHINE OIL.
- 5. ITEMS WITH QTY OF REF SPECIFIED (EXCEPT ITEMS 78 AND 79) ARE USED ON ITEM 46.
- 6 CUT TO LENGTH AT ASSY

TERMINAL NAME: Ø1MM CONTACT		CRIMP DATA (AMP TERMINAL)	
PAD LTR	CRIMP HEIGHT	WIRE SIZE	
A	.049 ±.002 [1.26 ±0.05mm]	1 mm ²	
B	.045 ±.002 [1.15 ±0.05mm]	0.75 mm ²	
C	.041 ±.002 [1.04 ±0.05mm]	0.5 mm ²	
D	NOT	USED	
CRIMP	SIZE	TYPE	RANGE
WIRE	.070 [1.78mm]	F	0.5mm ² - 1mm ²
INSUL	.100 [2.54mm]	OV	1.4 - 2.3mm

QTY REQD PER ASSY	TERMINAL NAME	TERM APPL SPEC	FEED	APPL INSTRUCTION	SET UP GAGE	LAYOUT	ITEM NO
2	2	2	-	C	3-354779-3	PIN, WIRE DISC (.3155)C	129
2	2	2	-	C	2-354779-4	PIN, WIRE DISC (.3110)B	127
2	2	2	-	C	1-354779-6	PIN, WIRE DISC (.3070)A	126
1	1	1	-	A	986950-1	WASHER, FLAT PRECISION	125
1	1	1	-	A	217238-1	GENERAL INSTRUCTION PACKAGE	124
1	1	1	-	-	4088040	SF APPL INST 408-8040	123
REF	REF	REF	-	A	1-21030-1	PIN, DOWEL (Ø.187x.50) LEVER	120
REF	REF	REF	-	A	1-21030-6	PIN, DOWEL (Ø.187x1.25) HOUSING	119
REF	REF	REF	-	A	21045-3	RING, RET "C" (Ø.187) FD FING PIN	118
1	1	1	-	A	21024-5	WASHER, LOCK (#10) ADJ BLOCK	117
REF	REF	REF	-	A	21024-5	WASHER, LOCK (#10) ADJ PLATE	116
REF	REF	REF	-	A	21024-5	WASHER, LOCK (#10) FEED GDE ROD	115
2	2	2	-	A	21024-2	WASHER, LOCK (#4) FRONT STP GUIDE	114
REF	REF	REF	-	A	5-21028-1	PIN, SLT SPR (Ø.125x.50) ADJ ROD	113
4	4	4	-	A	21024-4	WASHER, LOCK (#8) STRIPPER	112
REF	REF	REF	-	A	21899-4	WASHER, FLAT (Ø5/16) SCREW ADJ	110
1	1	1	-	A	21018-5	NUT, HEX (NO. 6) HOLDDOWN	109
REF	REF	REF	-	A	21068-5	NUT, HEX (6-32) FEED ADJ	107
1	1	1	-	A	992031-1	PIN, CLEVIS	105
1	1	1	-	A	21009-2	SCR, SKT SET (1/4-20x.25 LW) RAM	104
2	2	2	-	A	21017-2	SCR, DRIVE (#2x.19) ID PLATE	103
REF	REF	REF	-	A	6-23715-5	SCR, PAN HD (6-32x1.50) FEED ADJ	101
1	1	1	-	B	461264-1	PLATE, IDENTIFICATION	100
2	2	2	-	A	3-21002-0	SCR, BHC (10-32x.88) DRAG	99
1	1	1	-	A	22733-8	SCR, BHC (8-32x.38 LW) ANVIL	98
REF	REF	REF	-	A	2-21002-9	SCR, BHC (10-32x.75) CAP	97
REF	REF	REF	-	A	2-22733-8	SCR, BHC (1/4-20x.62) HOUSING	96
REF	REF	REF	-	A	2-21002-7	SCR, BHC (10-32x.50) SG ADJ BLOCK	95
6	6	6	-	A	2-21002-2	SCR, BHC (8-32x.50) TERM H DWN	94
1	1	1	-	A	1-21002-7	SCR, BHC (6-32x.38) CAM	93
1	1	1	-	A	1-21002-7	SCR, BHC (6-32x.38) CAM	92
1	1	1	-	A	1-21002-7	SCR, BHC (6-32x.38) CAM	91
1	1	1	-	A	7-21000-9	SCR, SHC (4-40x.19) STRIPPER	90
2	2	2	-	A	2-21000-7	SCR, SHC (8-32x.48) DEP-HOLD	89
1	1	1	-	A	2-22603-0	SCR, HEX HD (8-32x.31) FEED FINGER	88
2	2	2	-	A	1-21000-3	SCR, SHC (4-40x.25) F ST GUIDE	87
1	1	1	-	A	2-21000-7	SCR, SHC (8-32x.50) STRIPPER	86
REF	REF	REF	-	A	3-21000-7	SCR, SHC (10-32x.75) FEED ROD GD	85
REF	REF	REF	-	A	3-21000-6	SCR, SHC (10-32x.62) FD ADJ BLK	84
1	1	1	-	A	3-21000-4	SCR, SHC (10-32x.38) SG ADJ BL	83
REF	REF	REF	-	A	3-21000-4	SCR, SHC (10-32x.38) PIVOT BLK	82
-	REF	-	-	B	455749-1	GUARD, WINDOW	81
REF	-	-	-	B	679532-1	INSERT, GUARD	80
1	1	1	-	A	690603-1	SPRING, ASSIST	79
1	1	1	-	A	23030-1	SCR, SHC (6-32x.25 SL) INS DISC	78
REF	REF	REF	-	A	458109-1	WASHER, SPECIAL	77
REF	REF	REF	-	A	690517-1	SPACER	76
-3	-2	-1	U/M	DWG SIZE	PART NO	DESCRIPTION	ITEM NO

QTY REQD PER ASSY	LEADMAKER	MECH POST FEED	ITEM NO
-1	BENCH MODEL K	MECH PRE FEED	70
-2	BENCH MODEL G	MECH PRE FEED	69
-3	BENCH MODEL G	MECH PRE FEED	68
REF	REF	REF	22594-8
REF	REF	REF	240628-1
REF	REF	REF	240626-1
REF	REF	REF	240633-1
REF	REF	REF	455680-1
REF	REF	REF	240629-1
REF	REF	REF	240632-2
REF	REF	REF	240659-3
REF	REF	REF	240658-1
REF	REF	REF	454398-2
REF	REF	REF	454178-1
REF	REF	REF	454220-1
REF	REF	REF	454485-1
1	1	1	690542-2
REF	REF	REF	240624-1
REF	REF	REF	691499-1
REF	REF	REF	690541-1
REF	REF	REF	455679-1
REF	REF	REF	811242-2
1	1	1	690753-1
1	-	-	690602-6
-	1	-	690602-5
-	-	-	690501-4
1	1	1	459456-1
1	1	1	690191-1
1	1	1	455673-1
1	1	1	690125-1
1	1	1	690124-1
1	1	1	7-21002-9
1	1	1	23241-6
1	1	1	690170-1
1	1	1	690142-1
1	1	1	354777-1
1	1	1	22480-5
1	1	1	690212-1
1	1	1	2-690786-3
REF	REF	REF	455675-1
REF	REF	REF	455689-1
1	1	1	318756-1
1	1	1	1-455888-5
2	2	2	1-22284-0
1	1	1	690546-1
1	1	1	240792-1
1	1	1	6-690504-3
1	1	1	690438-1
-	-	1	690472-2
REF	REF	REF	4-22284-9
1	1	-	679218-1
1	1	-	458949-1
1	1	1	318563-1
1	1	1	5-22280-0
1	1	1	690461-1
1	1	1	690459-1
1	1	1	454276-1
1	1	1	1-662185-8
1	1	1	1-455889-4
1	1	1	238011-5
1	1	1	2-854830-4
1	1	1	455888-4
1	1	1	1-456404-8
-3	-2	-1	U/M

REVISION OF EACH ASSY NO (WHEN BLANK, USE DWG REVISION)

QTY REQD PER ASSY PARTS LIST

MATL HT TR FIN

DR B.HIGMAN 18SEP98 APP T.ELBIN 18SEP98

CHK 18SEP98 REL C.ERISMAN

NAME SIDE FEED HDM APPLICATOR MACHINE REF MINI APPL

SCALE 1 OF 1 SHEET 1 REV A

REMOVE BURRS, BREAK SHARP EDGES R.015 MAX

CUSTOMER AND ASSEMBLY DRAWING

00779 680695

THIS DRAWING IS A CONTROLLED DOCUMENT.

RELEASED FOR PUBLICATION DEC 29 1998 BY AMP INCORPORATED. ALL RIGHTS RESERVED. THIS DRAWING IS UNCLASSIFIED. COPYRIGHT 1998