

THIS DRAWING IS UNPUBLISHED. RELEASED FOR PUBLICATION
 © COPYRIGHT - By - ALL RIGHTS RESERVED.

LOC	DIST	REVISIONS			
P	LTR	DESCRIPTION	DATE	DWN	APVD
AF	52	B	REVISED PER ECR-14-006300	28AUG2014	MKD/RRP

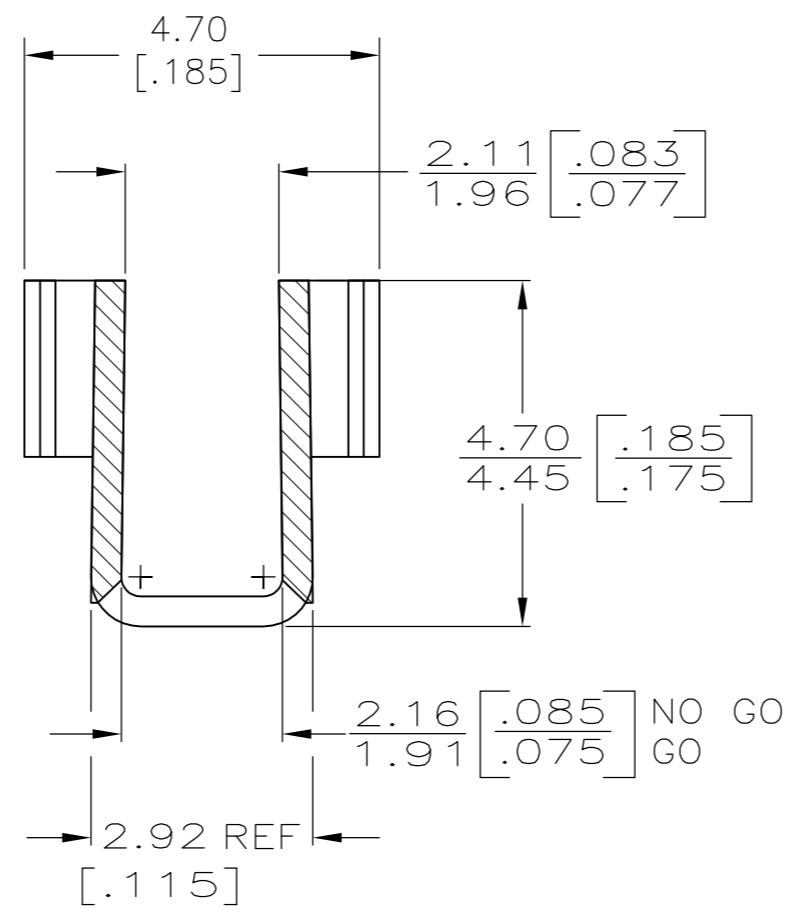

SECTION A-A
SCALE 10:1

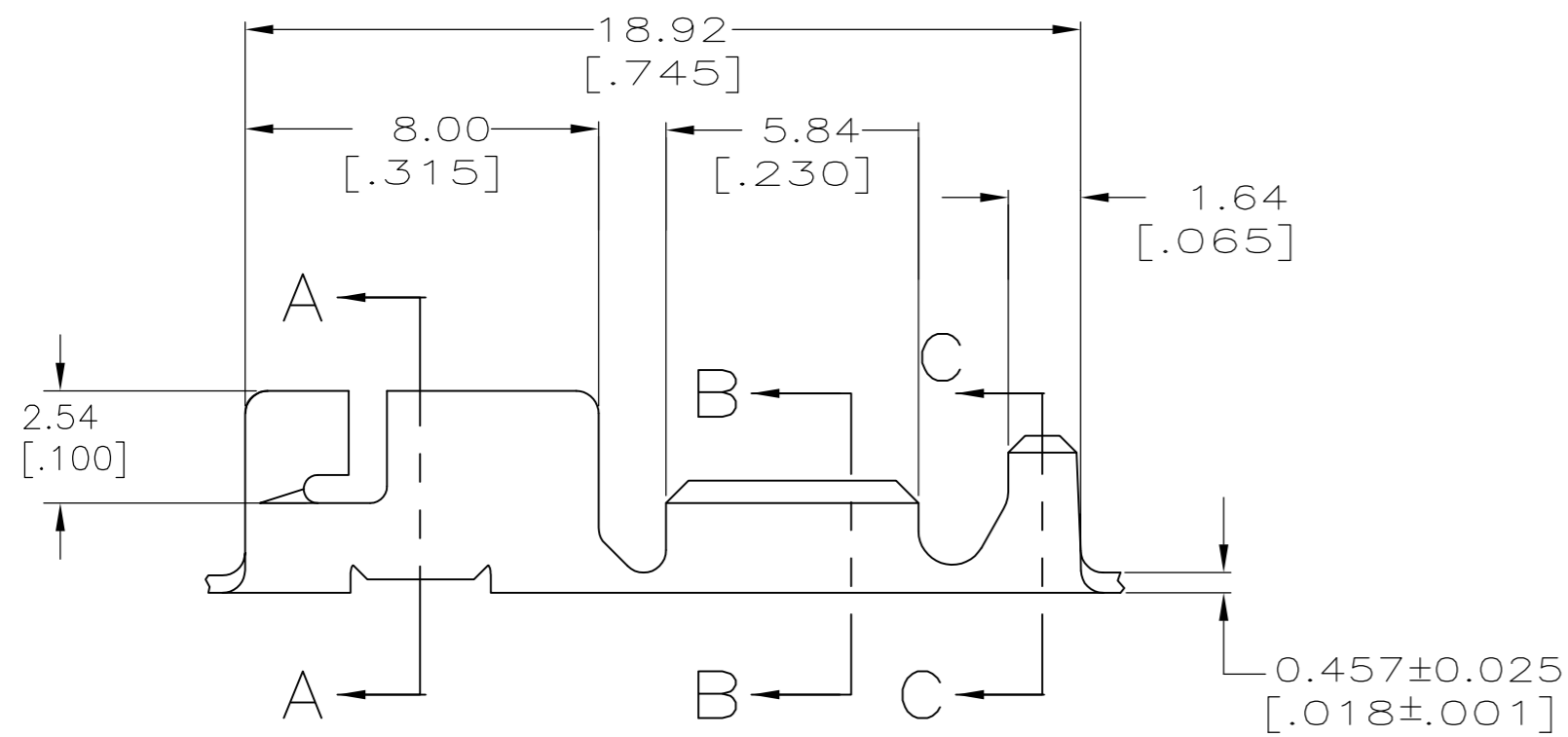
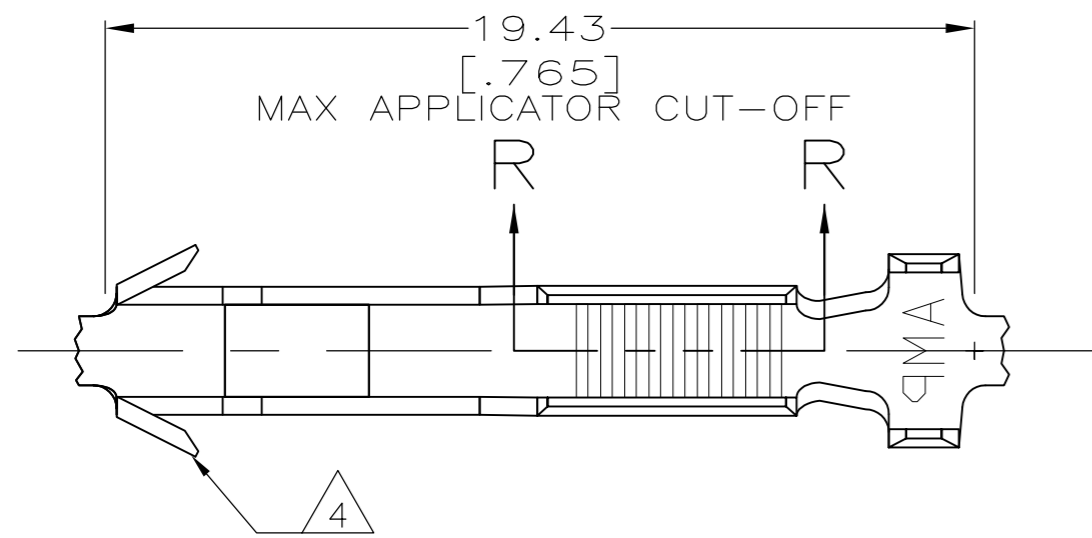
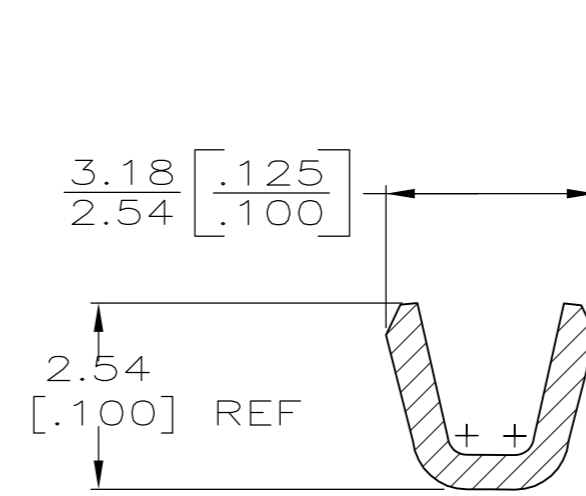

SECTION B-B
SCALE 10:1

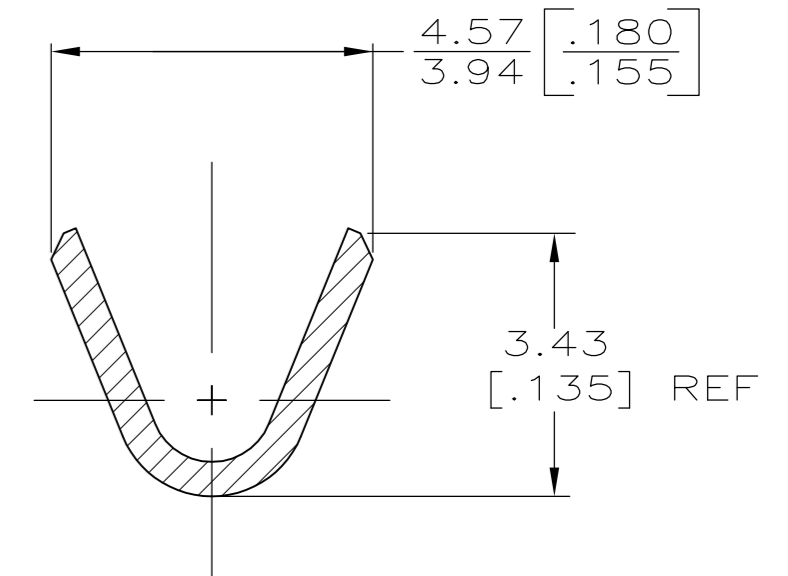

SECTION C-C
SCALE 10:1

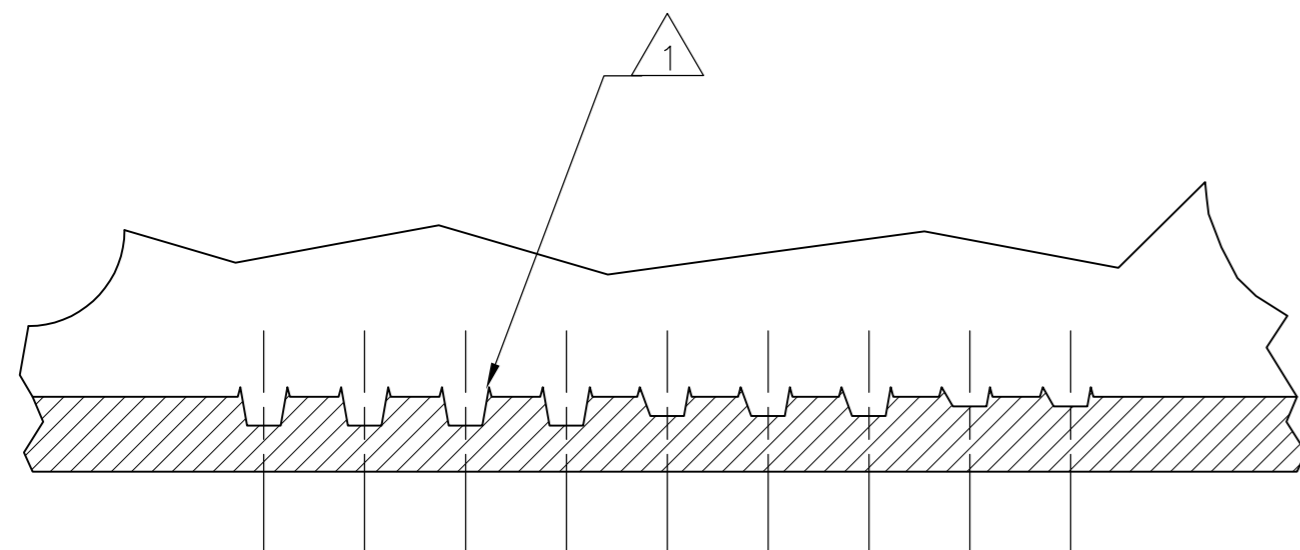

SECTION R-R
SCALE 25:1

- 1 AMPLIVAR SERRATIONS CONNECT UP TO 3 COPPER OR ALUMINUM MAGNET WIRES WITHOUT THE NEED TO REMOVE THE INSULATION
- 2 CONTACT TE ENGINEERING FOR ALUMINUM MAGNET WIRE
- 3 SUPPLIED AS CONTINUOUS STRIP WITH TERMINALS ON 21.21[.835] CENTERS.
- 4 HIGH RETENTION FEATURE

1.52-2.54 [.060-.100] DIA	400-1600 CMA COPPER	1742981-1
INSULATION RANGE	CMA WIRE RANGE	PART NUMBER

THIS DRAWING IS A CONTROLLED DOCUMENT.		DWN JR RUTH 08JUN12	TE Connectivity	
DIMENSIONS: mm [INCHES]		CHK GENE JACONO 08JUN12	RECEPTACLE, CLUSTER PIN, AMPLIVAR, 2.29 [.090] DIA	
TOLERANCES UNLESS OTHERWISE SPECIFIED:		APVD GENE JACONO 08JUN12	NAME	RESTRICTED TO
0 PLC ± -	1 PLC ± -	PRODUCT SPEC	108-2008	
2 PLC ± 0.25[.010]	3 PLC ± -	APPLICATION SPEC	114-2019	
4 PLC ± -	ANGLES ± -	WEIGHT	-	
MATERIAL H03 TIN-BRASS	FINISH TIN PLATED	SIZE	A2	
CUSTOMER DRAWING		CAGE CODE	00779	
SCALE		DRAWING NO	C=1742981	
6:1		SHEET	1 of 1	REV B