

LOC	DIST	ZONE	LTR	REVISIONS	DATE	APPD
G	14	A		REVISED PER 0720-0230-93	2/28/93	AMP

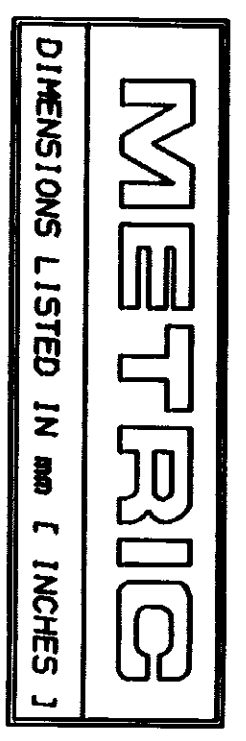

AMP WIRE RANGE	IL E13288 IL Listed
12-10 AWG STRANDED	12-10 AWG STRANDED
LR2189 Certified	MILITARY P/N AND CLASS
NOT CERTIFIED	NOT APPLICABLE

△ STAMP AMP 12-10\* APPROX AS SHOWN

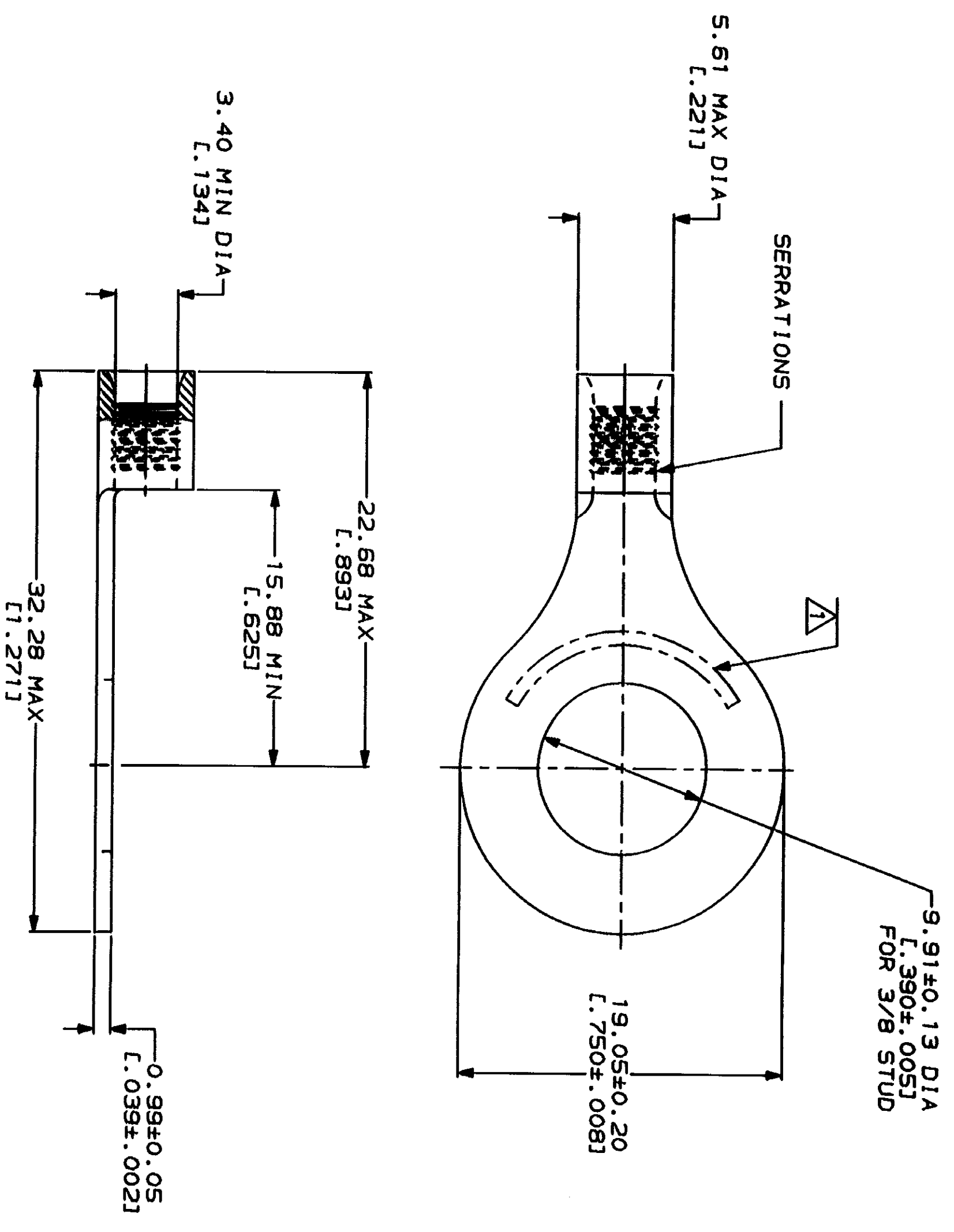

AMP INCORPORATED  
 CUSTOMER SERVICE SYSTEMS

FOR ADDITIONAL PRODUCT INFORMATION OR COPIES OF DRAWINGS AND TECHNICAL DOCUMENTS  
 1-800-522-6752

FOR APPLICATION TOOLING INFORMATION  
 1-800-722-1111

FOR ORDER ENTRY  
 1-800-526-5142

MAX RECOMMENDED OPERATING TEMPERATURE:  
 170°C MAX

VOLTAGE RATINGS:  
 NOT APPLICABLE

WIRE CROSS SECTIONAL AREA RANGE:  
 2.62-6.64mm<sup>2</sup> [5,180-13,100] CIR MILS  
 STRANDED

DO NOT SCALE PRINT. UNLESS SPECIFIED OTHERWISE, DIMENSIONS IN MILLIMETERS - TOLERANCES ON: 1. 2. PLC DEC ± .1 3. PLC DEC ± .1

MATERIAL: COPPER PER ASTM B-152 ANNEALED

FINISH: TIN PLATE  
 0.00254 [L.000100] MIN THK PER MIL-T-10727

DR	2-9-93	TA BRINKMAN
CHK	2-9-93	DA PATTERSON
APPD	2-9-93	DE MILLER
APPD	2-9-93	JL HECKLEY

APPLICATION SPEC

WEIGHT

AMP Incorporated  
 Harrisburg, PA 17105-3608

TERMINAL, RING TONGUE, BUDGET

SIZE CASE CODE 00779 DRAWING NO. C-34833 SCALE 4:1 SHEET 1 OF 1

CUSTOMER DRAWING