

THIS DRAWING IS UNPUBLISHED. RELEASED FOR PUBLICATION  
 © COPYRIGHT - By - ALL RIGHTS RESERVED.

LOC		DIST		REVISIONS			
P	LTR	DESCRIPTION		DATE	DWN	APVD	
AA	00	B2	REVISED PER ECO-11-005033	29MAR11	RK	HMR	

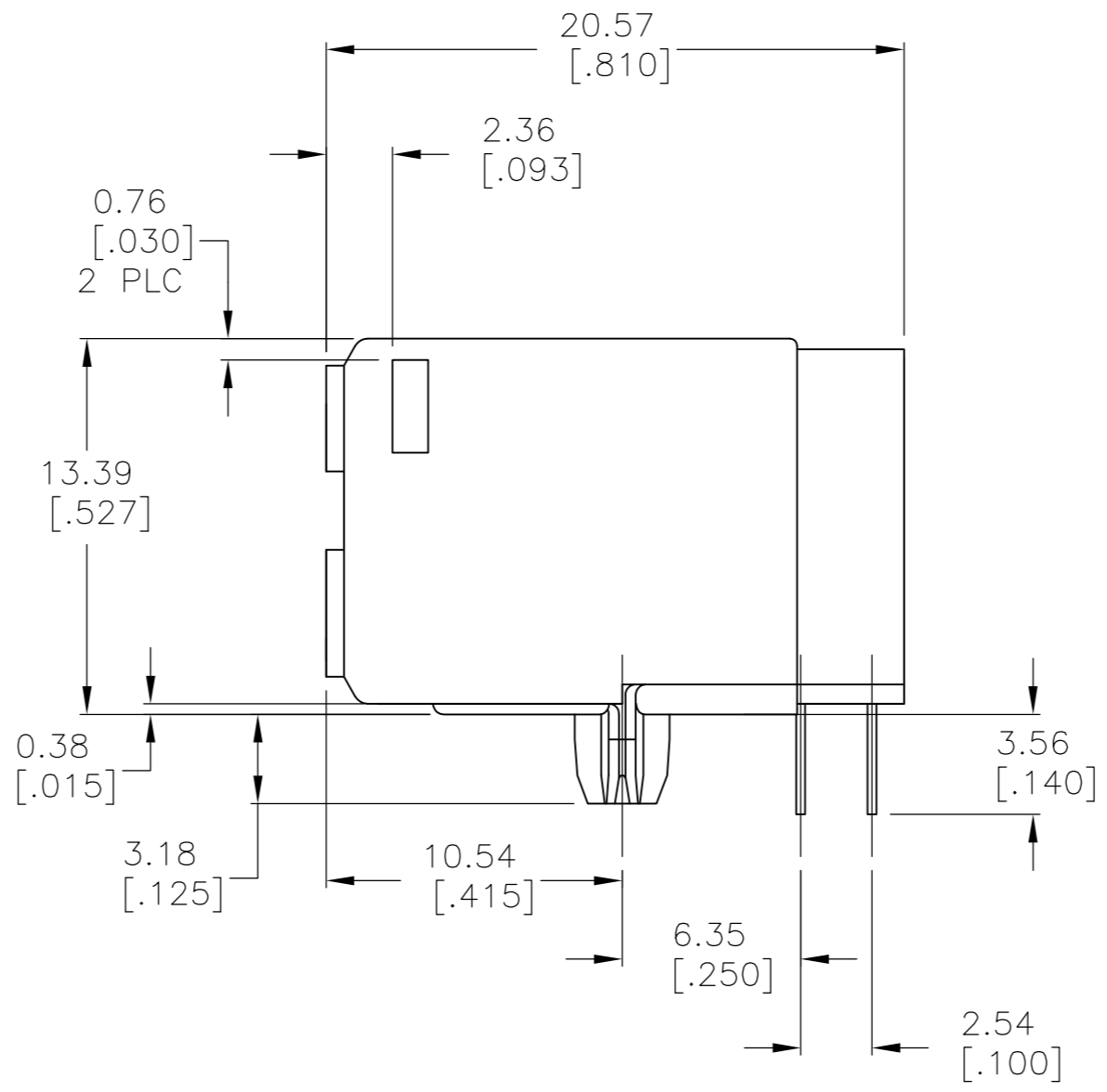

- ⚠ MATERIAL: HOUSING—HIGH TEMPERATURE NYLON, BLACK, UL 94V-0.  
TERMINALS - 0.33[.013] THICK PHOS BRONZE PLATED WITH 1.27μm[.000050] MINIMUM THICK HARD GOLD IN LOCALIZED AREA AND 3.81μm [.000150] MINIMUM THICK MATTE TIN IN SOLDER AREA OVER 1.27μm[.000050] MINIMUM THICK NICKEL UNDERPLATE.
- ⚠ JACK CAVITY CONFORMS TO FCC RULES AND REGULATIONS, PART 68 SUBPART F.
- ⚠ CAUTION: CATEGORY 5 JACK SOLDER TAIL POSITIONS DO NOT FOLLOW SAME NUMBER SEQUENCE AS THAT OF TRADITIONAL JACKS.
- ⚠ USE #30 DRILL BIT OR 3.25mm DRILL BIT WHEN PRODUCING THESE PCB HOLES.

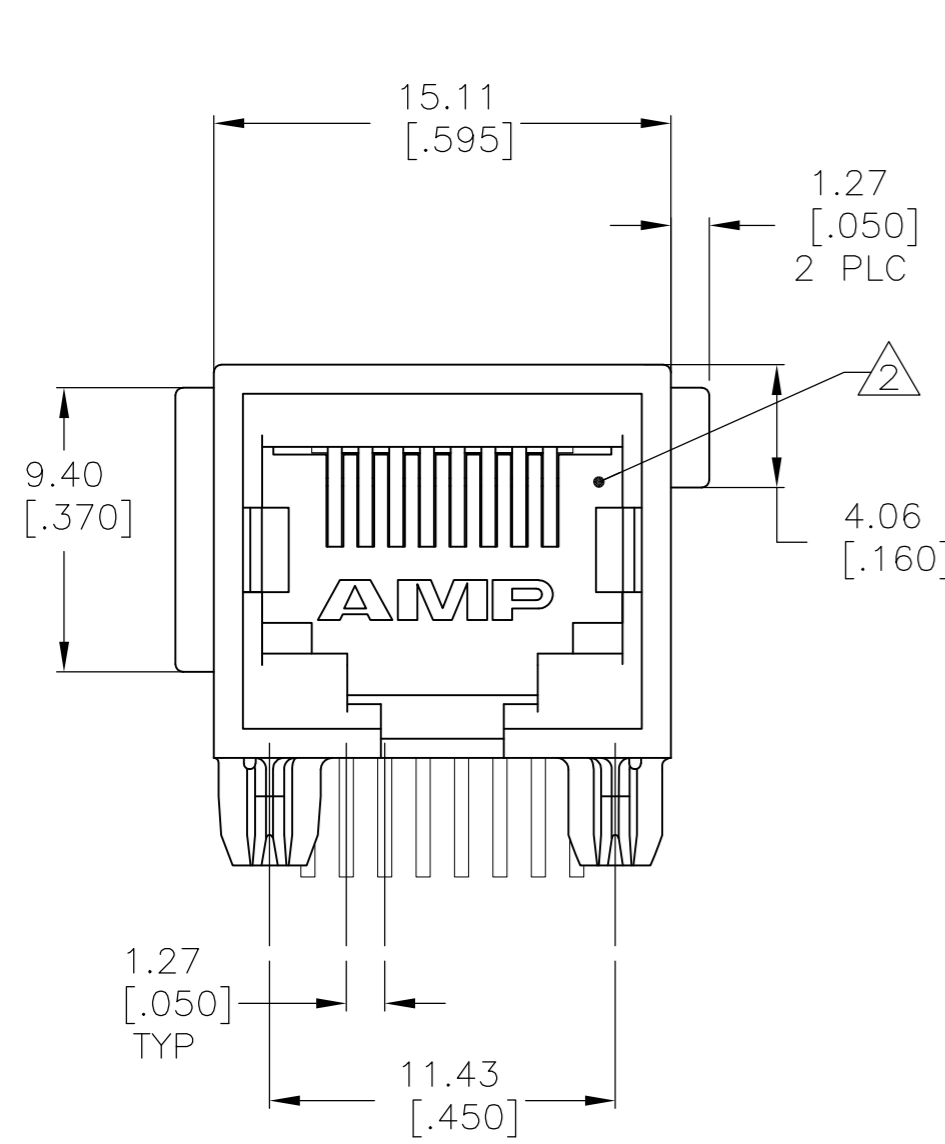
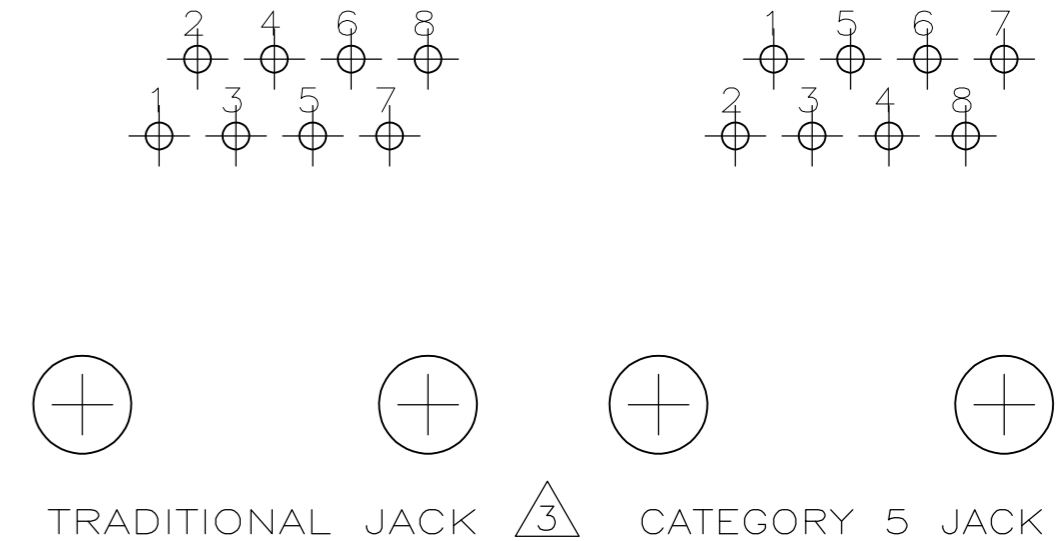
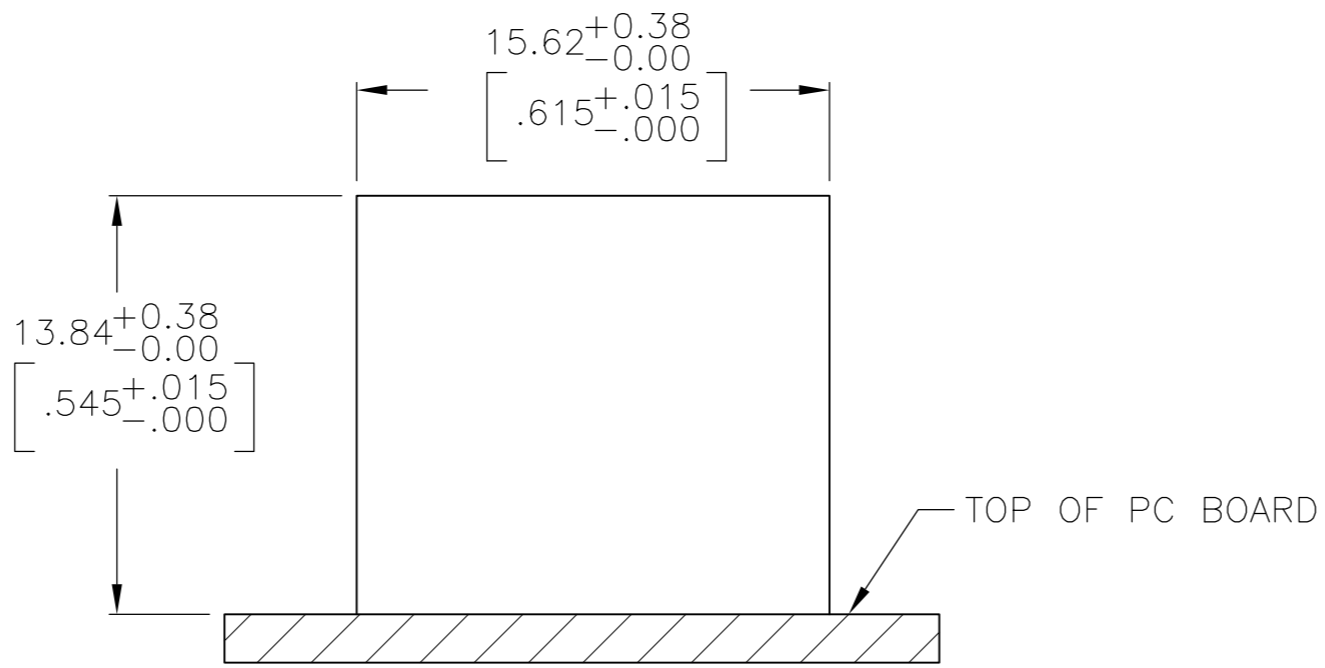
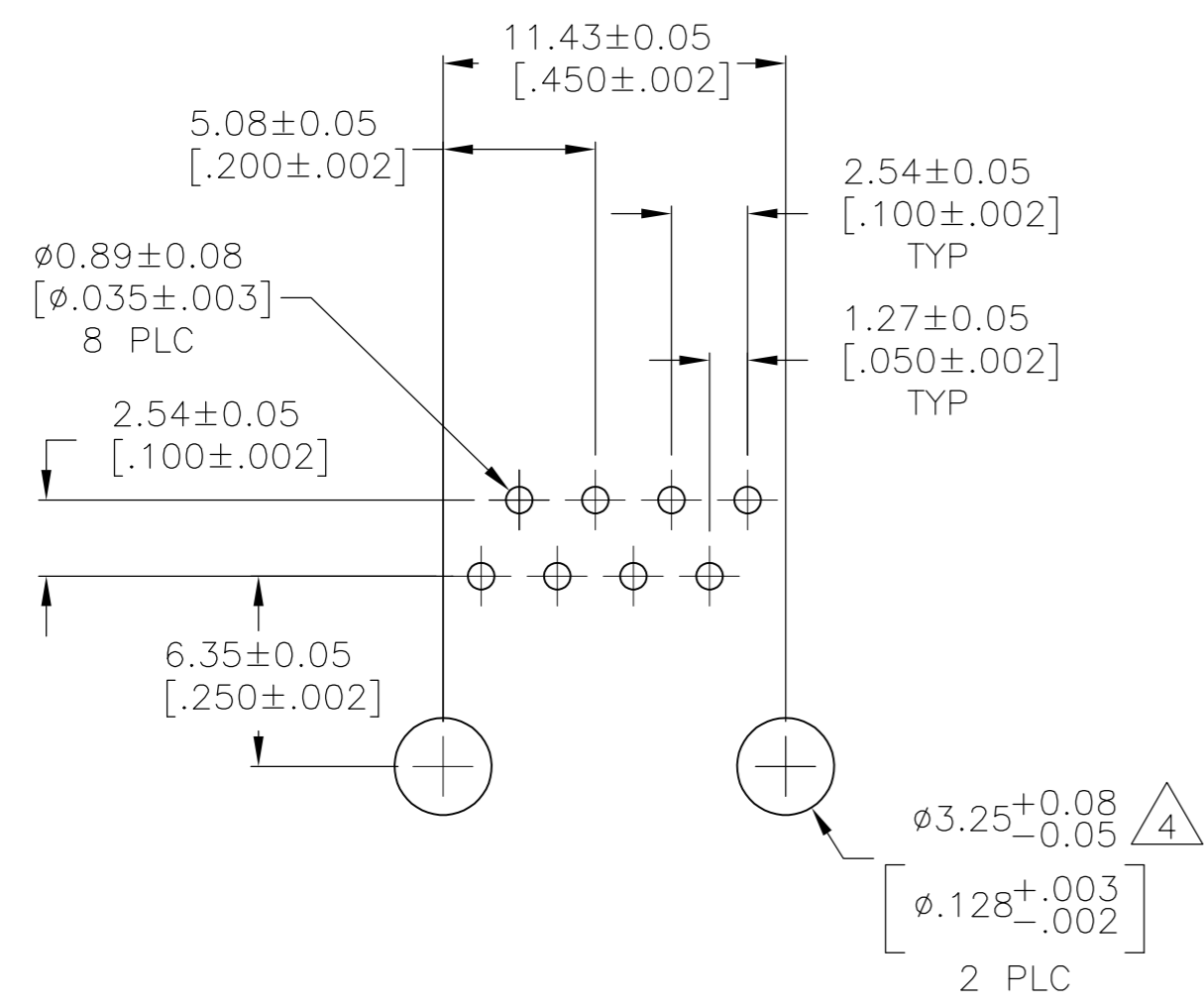

SUGGESTED PC BOARD LAYOUT  
COMPONENT SIDE

SUGGESTED PANEL CUTOUT  
SCALE 2:1

THIS DRAWING IS A CONTROLLED DOCUMENT.		DWN B. LATTUCA 20SEPT05	TE Connectivity	
DIMENSIONS: mm [INCHES]		CHK J. WESTMAN 20SEPT05		
TOLERANCES UNLESS OTHERWISE SPECIFIED:		APVD S. FLICKINGER 20SEPT05	NAME	
0 PLC ± - 1 PLC ± - 2 PLC ± 0.25[.010] 3 PLC ± - 4 PLC ± - ANGLES ± - FINISH SEE NOTE 1		PRODUCT SPEC 108-1163	MODULAR JACK ASSEMBLY, 8 POSITION, RIGHT ANGLE, LOW PROFILE, CATEGORY 5, WITH PANEL STOPS	
MATERIAL SEE NOTE 1		APPLICATION SPEC 114-2048	SIZE A2	CAGE CODE 00779
		WEIGHT -	DRAWING NO C=5558343	RESTRICTED TO -
		CUSTOMER DRAWING	SCALE 4:1	SHEET 1 of 1
			REV B2	