

LOC		DIST		REVISIONS				DATE	APPD
AF	50	P	F	ZONE	LTR	DESCRIPTION			
					D	REV PER 0710-0196-96	18JUN96	RG/NN	

- ① SLOT ACCEPTS 0.25-0.32mm [#30-#28] AWG COPPER MAGNET WIRE.
- ② 0.002032[.000080] MIN TIN PER MIL-T-10727 OVER 0.00127[.000050] MIN NICKEL PER QQ-N-290

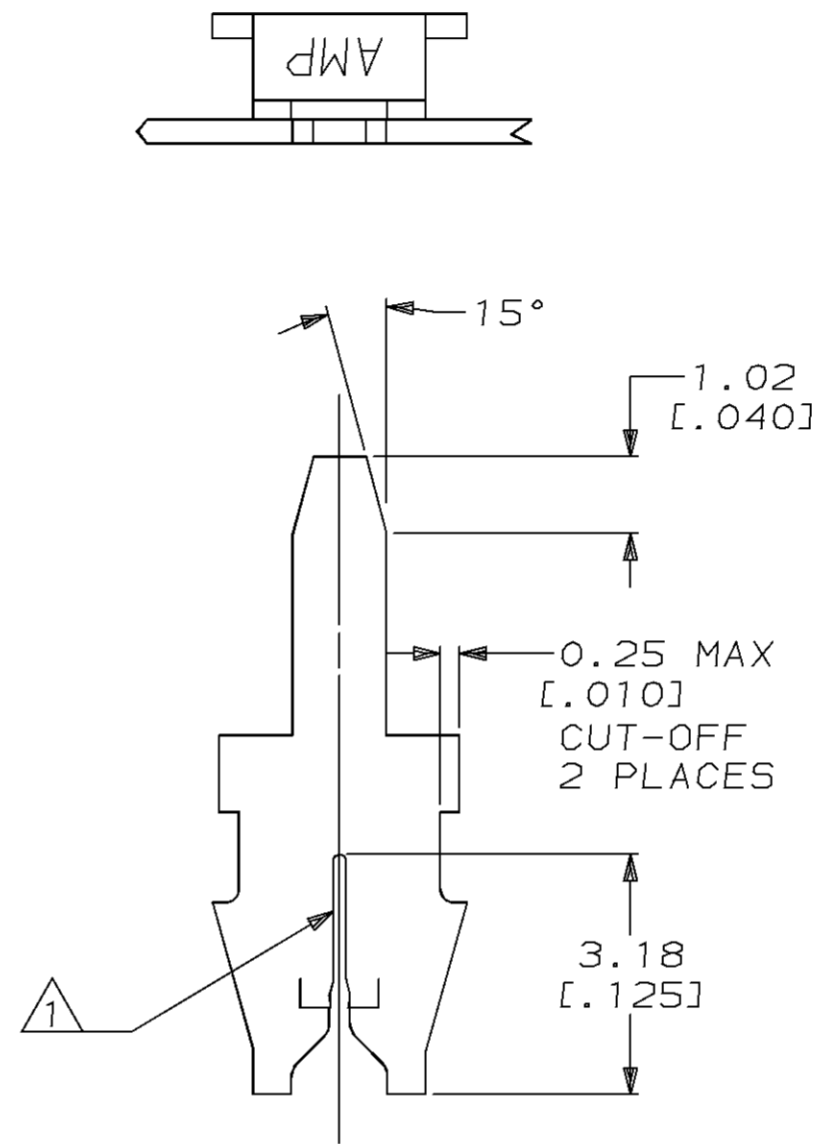
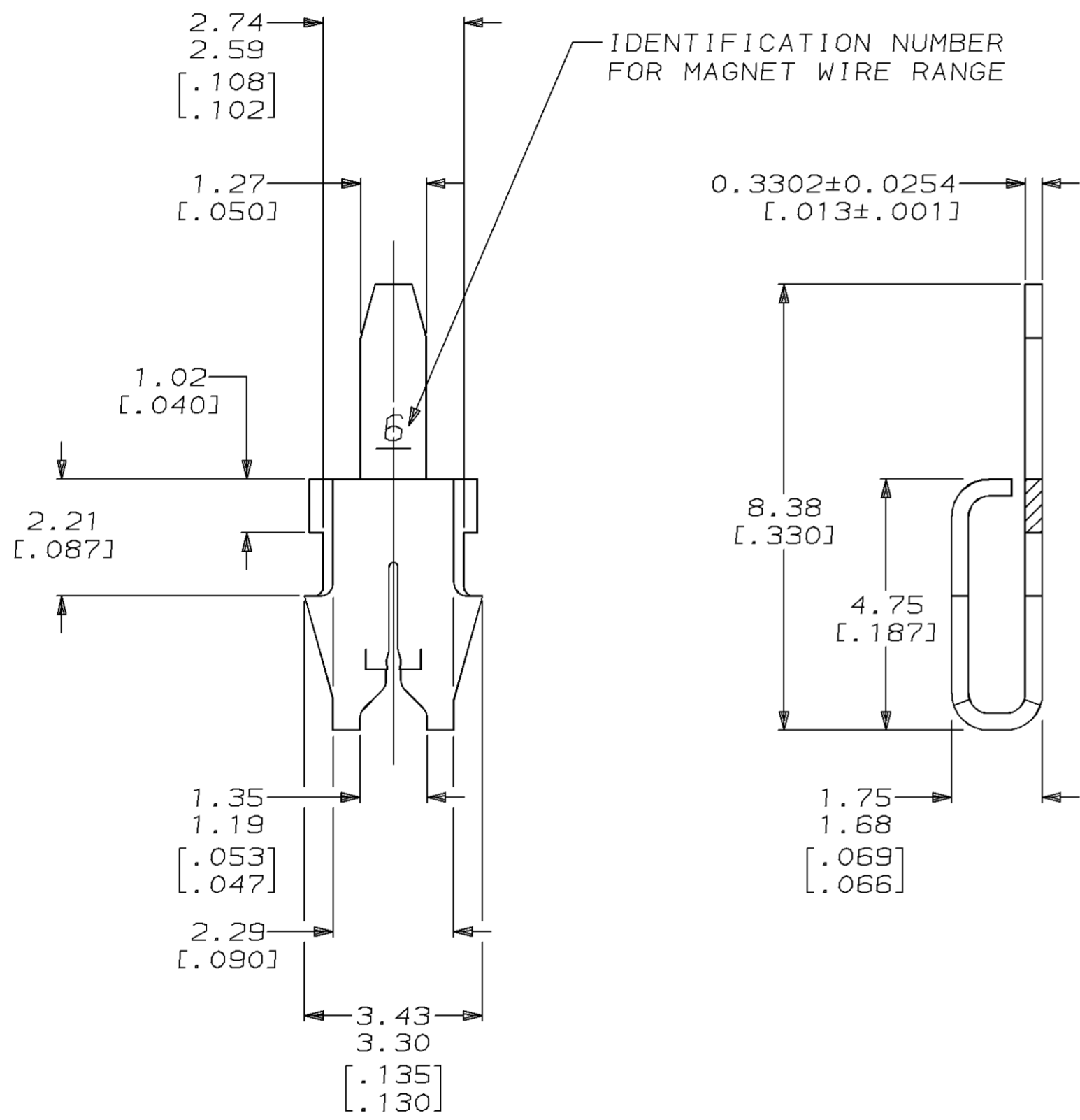

DO NOT SCALE PRINT. UNLESS SPECIFIED DIMENSIONS IN mm [INCHES] TOLERANCES ON : 2 PLC DEC ± 0.25 [.010] 3 PLC DEC ± - ANGLES ± -		DR 25/MAY/94 R.R. BUCHHEISTER		AMP Incorporated Harrisburg, PA 17105-3608	
MATERIAL H04 BRASS		CHK 26/MAY/94 M.S. FEHER			
FINISH ②		APPD 06/JUN/94 T.L. SHUTTER		NAME TERMINAL, POSTED, LOOSE PIECE, MAG-MATE™	
THIS DRAWING IS A CONTROLLED DOCUMENT FOR AMP INCORPORATED. IT IS SUBJECT TO CHANGE AND THE CONTROLLING ENGINEERING ORGANIZATION SHOULD BE CONTACTED FOR THE LATEST REVISION.		APPLICATION SPEC 114-2069		SIZE C	CAGE CODE 00779
		WEIGHT -		DRAWING NO G-62874	SHEET 1 OF 1