



**ARM Reference Board  
Application Note**

Document Number: EB\_ARMAT91\_XXAXX\_B  
Revision: 1.2  
Release Date: 08/11/2010

# InvenSense ARM Reference Board Application Note

A printed copy of this document is **NOT UNDER REVISION CONTROL** unless it is dated and stamped in red ink as, "REVISION CONTROLLED COPY."



## ARM Reference Board Application Note

Document Number: EB\_ARMAT91\_XXAXX\_B  
Revision: 1.2  
Release Date: 08/11/2010

### 1. Revision History

Date	Revision	Description
05/26/2010	1.0	Initial release
06/23/2010	1.1	Updated BOM, added mechanical drawings for select components, added firmware revision note.
08/11/2010	1.2	Updated firmware revision in Section 10.



## CONTENTS

1.	REVISION HISTORY .....	2
2.	PURPOSE .....	4
3.	USAGE .....	4
4.	OTHER DOCUMENTS .....	4
5.	SCHEMATIC .....	5
6.	BOARD PHOTO .....	6
7.	COMPONENT LAYER SILK SCREEN.....	7
8.	TABLE 1. BILL OF MATERIALS (PARTS STUFFING LIST).....	8
9.	MECHANICAL DRAWINGS FOR SELECTED BOM ITEMS .....	9
10.	PROGRAMMING THE ARM AT91 MCU.....	11

## 2. Purpose

This document describes the hardware and circuitry of the RB\_ARMAT91\_XXAXX\_A reference board (also known as InvenSense ARM board).

## 3. Usage

This reference board provides a bridge function between InvenSense evaluation boards and a PC. It connects to a PC via USB and to InvenSense evaluation boards via SPI or I<sup>2</sup>C. The figure below shows the ARM board connecting an IMU-3000 evaluation board to a Windows PC. (Note that the ARM board is used as a general-purpose bridge and can also be used with other InvenSense EVBs, including the ITG-3xxx and MPU-3xxx family of devices.) The ARM processor on the reference board is not meant to be reprogrammed by the user. It contains all code necessary to be used in conjunction InvenSense evaluation boards. Note that separate demonstration software may accompany the individual evaluation boards with which this device connects.

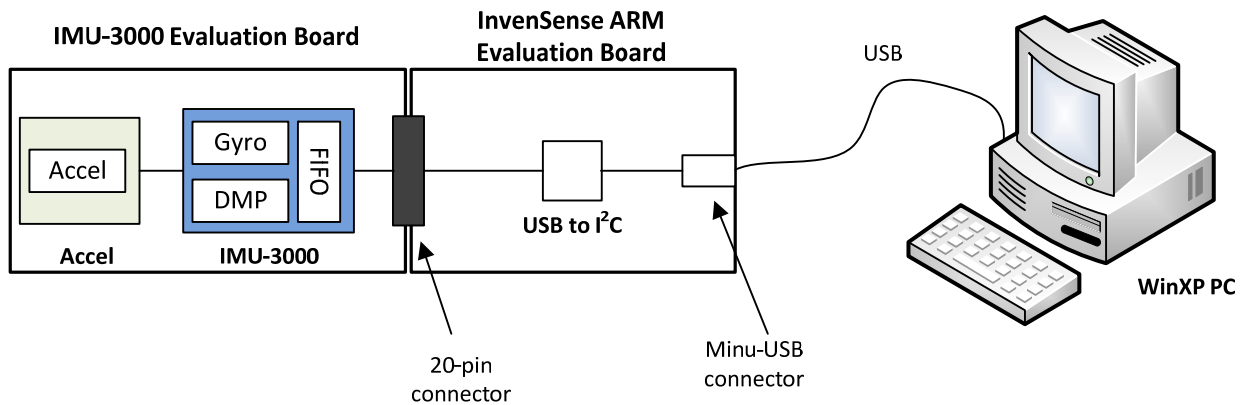

**Figure 1. Example of ARM Board Used as Bridge between PC and IMU-3000 Evaluation Board. Note that the ARM board is used as a general-purpose bridge and can also be used with other InvenSense EVBs, including the ITG-3xxx and MPU-3xxx family of devices.**

## 4. Other Documents

Since the ARM board is meant to bridge between InvenSense evaluation boards and a PC, this document should be used in conjunction with the documents related to the particular board that is being used with the ARM Board.

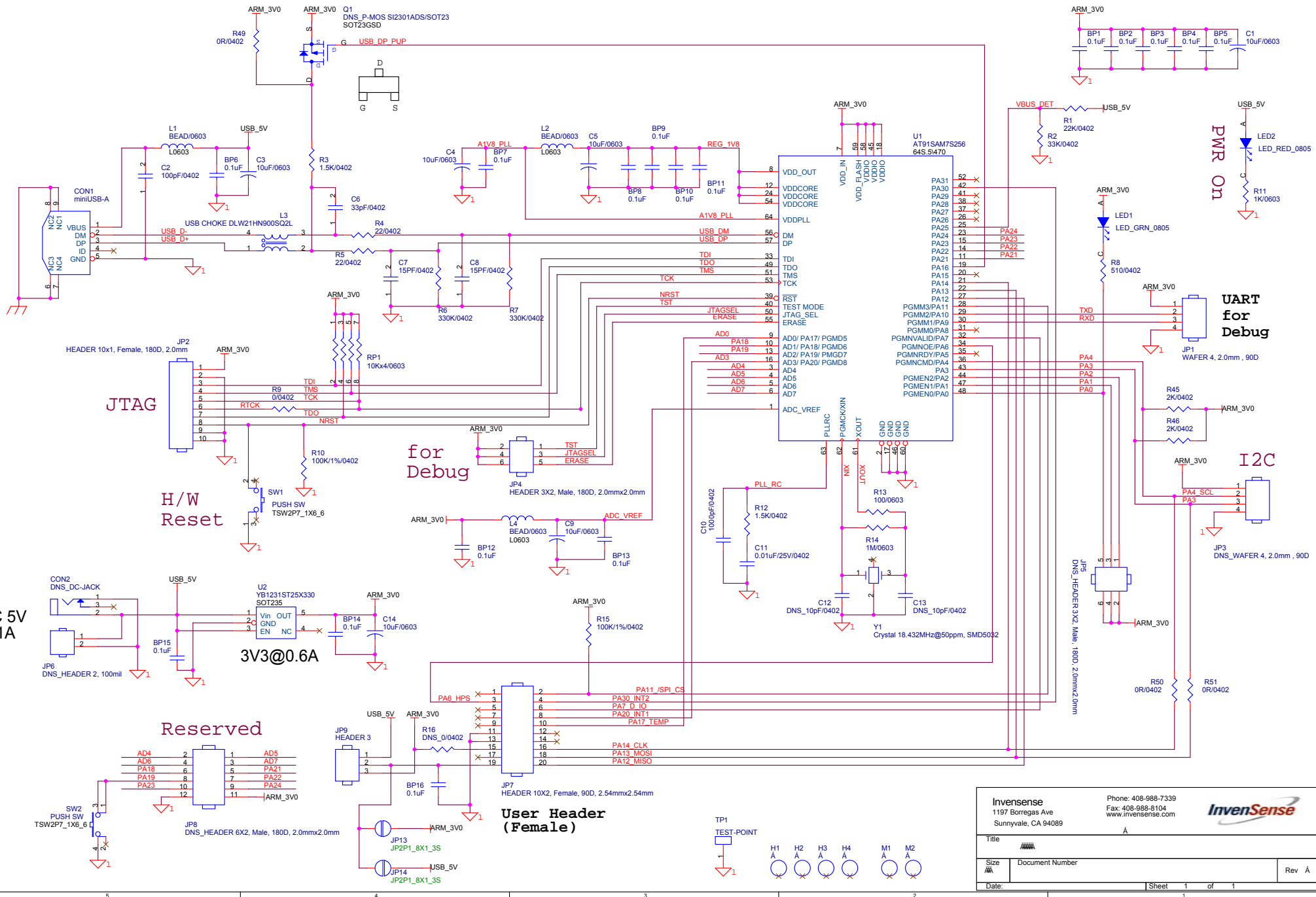

<b>Invensense</b> 1197 Borregas Ave Sunnyvale, CA 94089		Phone: 408-988-7339 Fax: 408-988-8104 www.invensense.com		
Title	ARM Reference Board	Rev A		
Size	Document Number	Rev A		
Date:	Sheet 1 of 1			

## 6. Board Photo

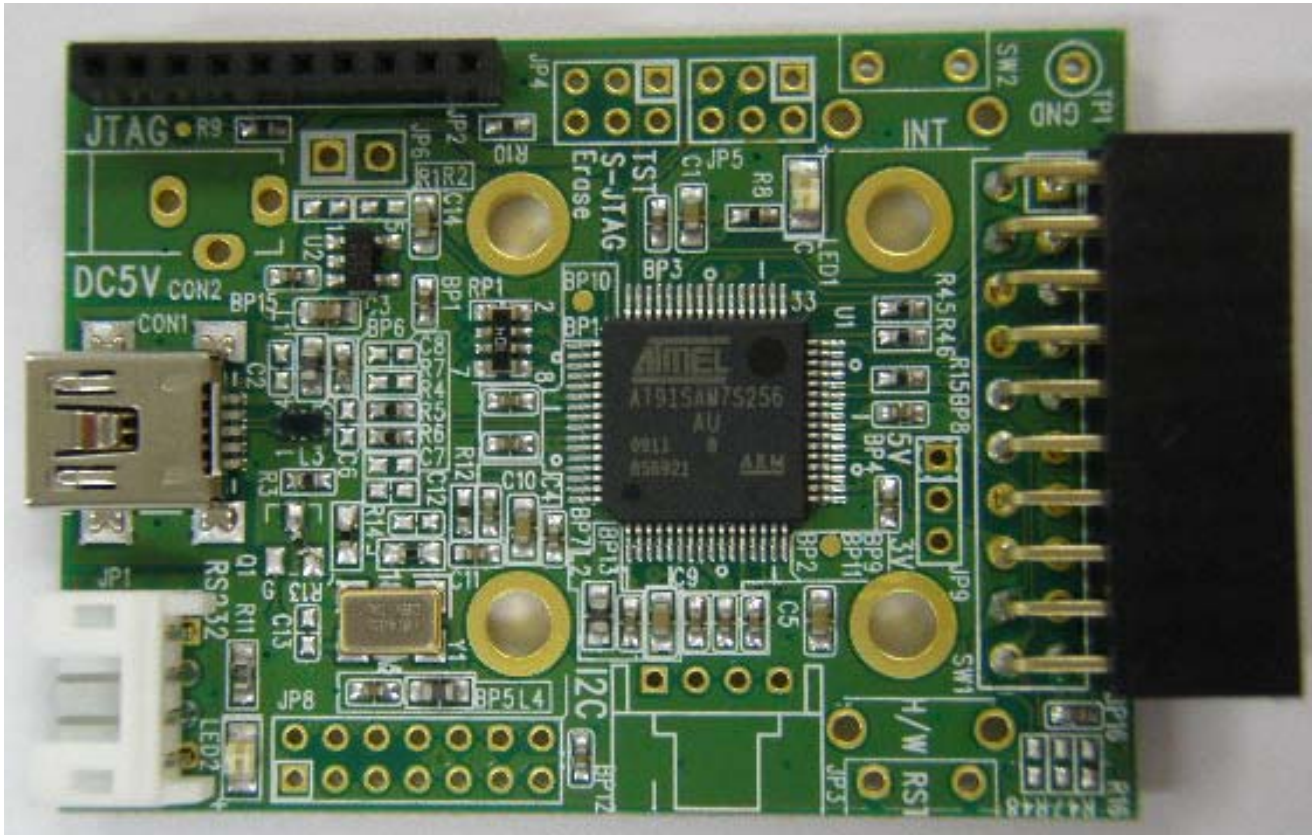
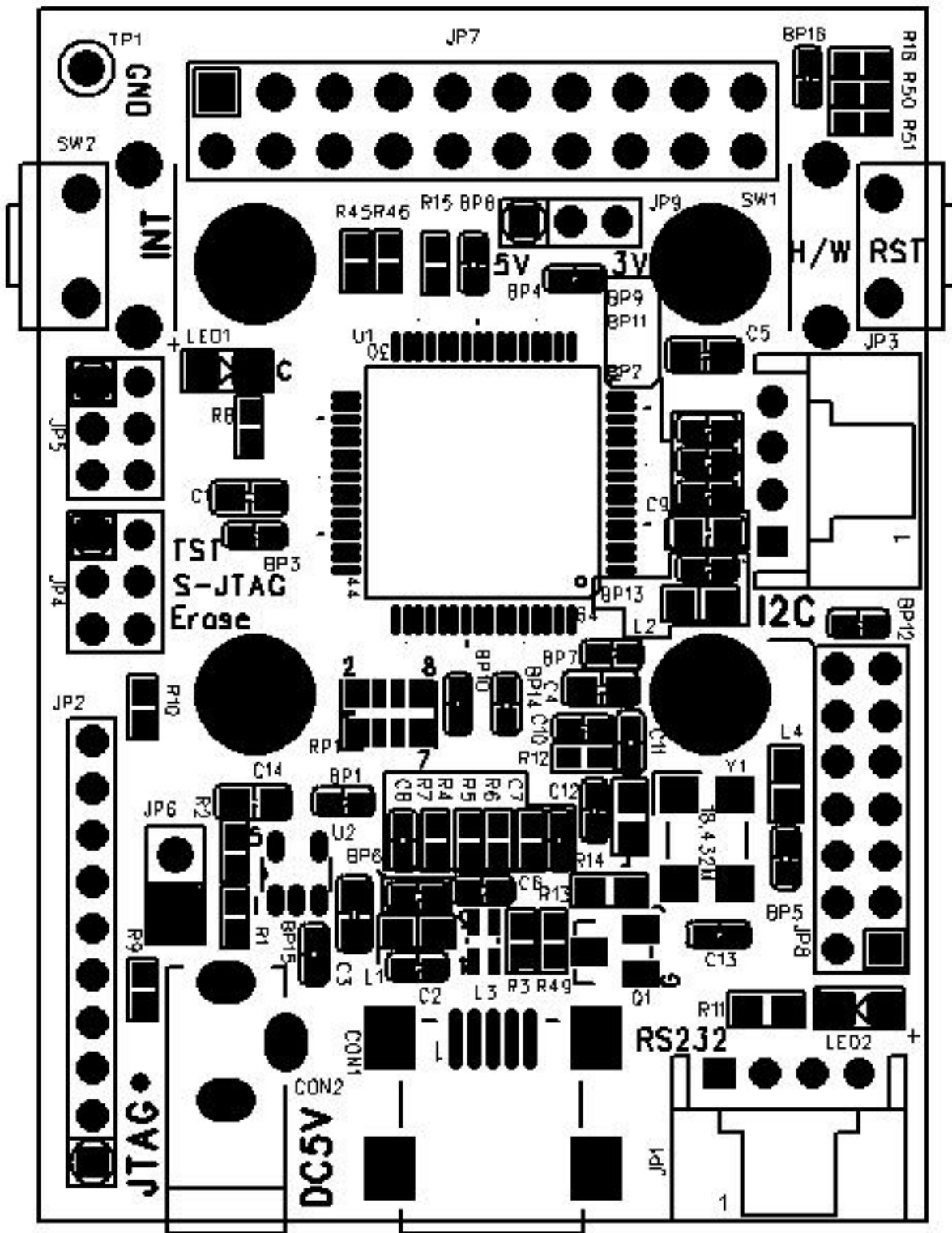

Figure 3. Component-layer board photo

**7. Component Layer Silk Screen**



**Figure 4. Component-layer silk screen**



## ARM Reference Board Application Note

Document Number: EB\_ARMAT91\_XXAXX\_B  
Revision: 1.2  
Release Date: 08/11/2010

### 8. Table 1. Bill of Materials (Parts Stuffing List)

Item	Quantity	Reference	Part	PCB Footprint
1	16	BP1,BP2,BP3,BP4,BP5,BP6,BP7,BP8,BP9, BP10,BP11,BP12,BP13,BP14,BP15,BP16	0.1uF	C0402
2	1	CON1	miniUSB-A	USB\MINI
3	1	CON2 (DO NOT STUFF)	DC Jack	
4	6	C1,C3,C4,C5,C9,C14	10uF/0603	C0603
5	1	C2	100pF/0402	C0402
6	1	C6	33pF/0402	C0402
7	2	C7,C8	15PF/0402	C0402
8	1	C10	1000pF/0402	C0402
9	1	C11	0.01uF/25V/0402	C0402
10	1	C12 (DO NOT STUFF)	10pF/0402	
11	1	C13 (DO NOT STUFF)	10pF/0402	
12	1	JP1	WAFER 4, 80mil, ANGLE	J79\4SA90
13	1	JP2	HEADER 10, 80mil, Angle, Female	J79\10S
14	1	JP3 (DO NOT STUFF)	HEADER 4, 80mil	
15	1	JP4	HEADER 3X2, 80mil	J79\6D
16	1	JP5 (DO NOT STUFF)	HEADER 3x2, 2mmx2mm, Male	
17	1	JP6 (DO NOT STUFF)	HEADER 2, 100mil	
18	1	JP7	HEADER 10X2, 100mil, Female	J100\20DF
19	1	JP8 (DO NOT STUFF)	HEADER 6X2, 2mmx2mm, Male	
20	1	JP9	HEADER 3	J79\3S
21	1	LED1	LED_GRN_0805	LED0805AC
22	1	LED2	LED_RED_0805	LED0805AC
23	3	L1,L2,L4	BEAD/0603	L0603
24	1	L3	CHOKE CM3216W900H	CH4P1_25X2_05S
25	1	Q1 (DO NOT STUFF)	P-FET SI2301ADS/SOT23	
26	1	RP1	10Kx4/RP4A0603	RN8P06SN
27	1	R1	22K/0402	R0402
28	1	R2	33K/0402	R0402
29	2	R3,R12	1.5K/0402	R0402
30	2	R4,R5	33/0402	R0402
31	2	R6,R7	330K/0402	R0402
32	1	R8	510/0402	R0402
33	4	R9, R49, R50, R51	0/0402	R0402
34	1	R16 (DO NOT STUFF)	0/0402	
35	2	R10,R15	100K/1%/0402	R0402
36	1	R11	1K/0603	R0603
37	1	R13	100/0603	R0603
38	1	R14	1M/0603	R0603
39	2	R45,R46	2K/0402	R0402
40	1	SW1 (DO NOT STUFF)	PUSH SW	TSW2P7_1X6_6
41	1	SW2 (DO NOT STUFF)	PUSH SW	TSW2P7_1X6_6
42	1	U1	ARM AT91SAM7S64	64S.5\470
43	1	U2	3V3 LDO YB1231ST25X330	SOT235
44	1	Y1	Crystal 18.432MHz@50ppm, SMD5032	SX-5032
45	1	Blank Printed Circuit Board	Gerber_ARM_EVb.rar	
46	1	Firmware for ARM	V1.1.1 Firmware for ARM MCU	



**9. Mechanical Drawings for Selected BOM Items**

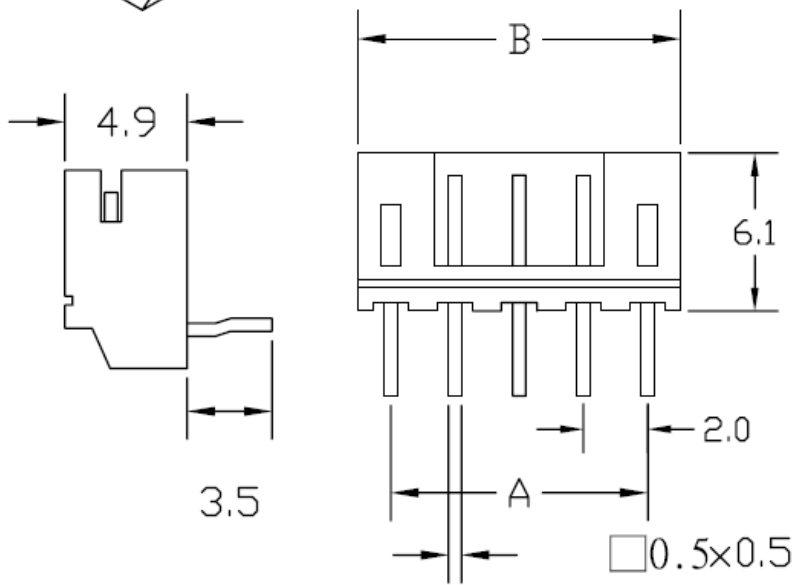
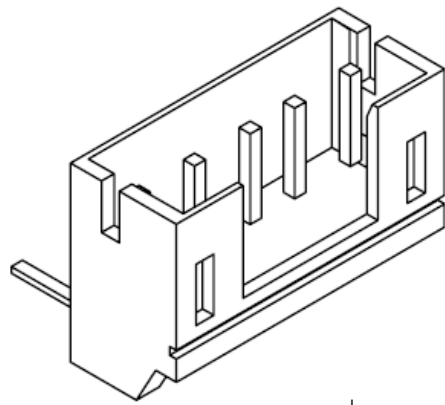

Pos.	dimension mm	
	A	B
2	2.0	6.0
3	4.0	8.0
4	6.0	10.0
5	8.0	12.0
6	10.0	14.0
7	12.0	16.0
8	14.0	18.0
9	16.0	20.0
10	18.0	22.0

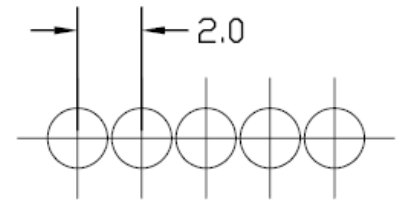

PCB LAYOUT

**Figure 5. BOM Item #12, JP1 Drawing**

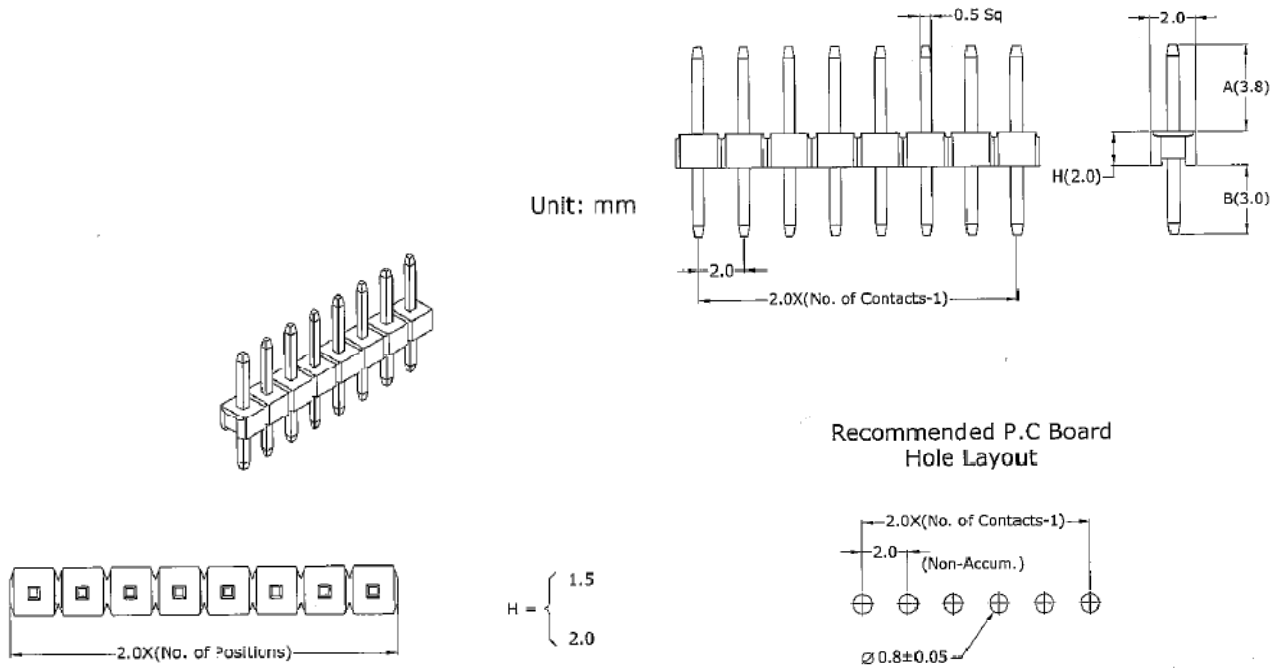

**Figure 6. BOM Item #20, JP9 Drawing (3-Pin Header)**

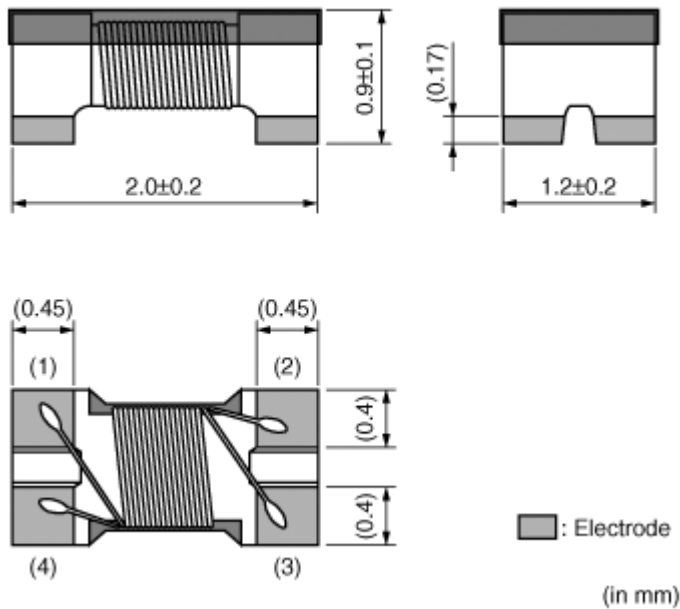

**Figure 7. BOM Item #24, L3 Drawing**



## ARM Reference Board Application Note

Document Number: EB\_ARMAT91\_XXAXX\_B  
Revision: 1.2  
Release Date: 08/11/2010

### 10. Programming the ARM AT91 MCU

The firmware for the InvenSense ARM Board must be factory programmed using the JTAG port JP2 with Atmel's programming tool and software. The current firmware revision is V1.1.2EVB. For upgrading boards that have an older firmware revision, the ARM MCU may only be programmed by InvenSense or its designated representatives.

This information furnished by InvenSense is believed to be accurate and reliable. However, no responsibility is assumed by InvenSense for its use, or for any infringements of patents or other rights of third parties that may result from its use. Specifications are subject to change without notice. InvenSense reserves the right to make changes to this product, including its circuits and software, in order to improve its design and/or performance, without prior notice. InvenSense makes no warranties, neither expressed nor implied, regarding the information and specifications contained in this document. InvenSense assumes no responsibility for any claims or damages arising from information contained in this document, or from the use of products and services detailed therein. This includes, but is not limited to, claims or damages based on the infringement of patents, copyrights, mask work and/or other intellectual property rights.

Certain intellectual property owned by InvenSense and described in this document is patent protected. No license is granted by implication or otherwise under any patent or patent rights of InvenSense. This publication supersedes and replaces all information previously supplied. Trademarks that are registered trademarks are the property of their respective companies. InvenSense sensors should not be used or sold in the development, storage, production or utilization of any conventional or mass-destructive weapons or any other weapons or life threatening applications, as well as in any other life critical applications such as medical equipment, transportation, aerospace and nuclear instruments, undersea equipment, power plant equipment, disaster prevention and crime prevention equipment.

©2010 InvenSense, Inc. All rights reserved.

