

© 1965 BY AMP INCORPORATED. ALL RIGHTS RESERVED. AMP PRODUCTS COVERED BY PATENTS AND/OR PATENTS PENDING. APPROVED PER GOVT CONTRACT NO.

NUMBER 202795

REVISIONS				
SYM	ZONE	DESCRIPTION	DATE	APPROVAL
A		REVISED	Y-68	1-19-66 m.S. J.H.
B		REVISED	Y-296	3-22-66 m.S. J.H.
C		REV PER ECN D-644		10-6-75
D		ADDED -3 PER ECN H-373		11-5-80 ESE JH
E		REV. / ECN R-2305		7-20-86 MPH gmf
F		OBSOLETE -3 PER ECN R-2604		2-23-87 SDG JLB
F1		ADDED -4 PER ECN DF-0026	OCT	10-2-87 JW
G		REV PER ECU-05-001A12	AA	05/05 DR
H		REV PER ECO-05-005359		11/05 PY/DE

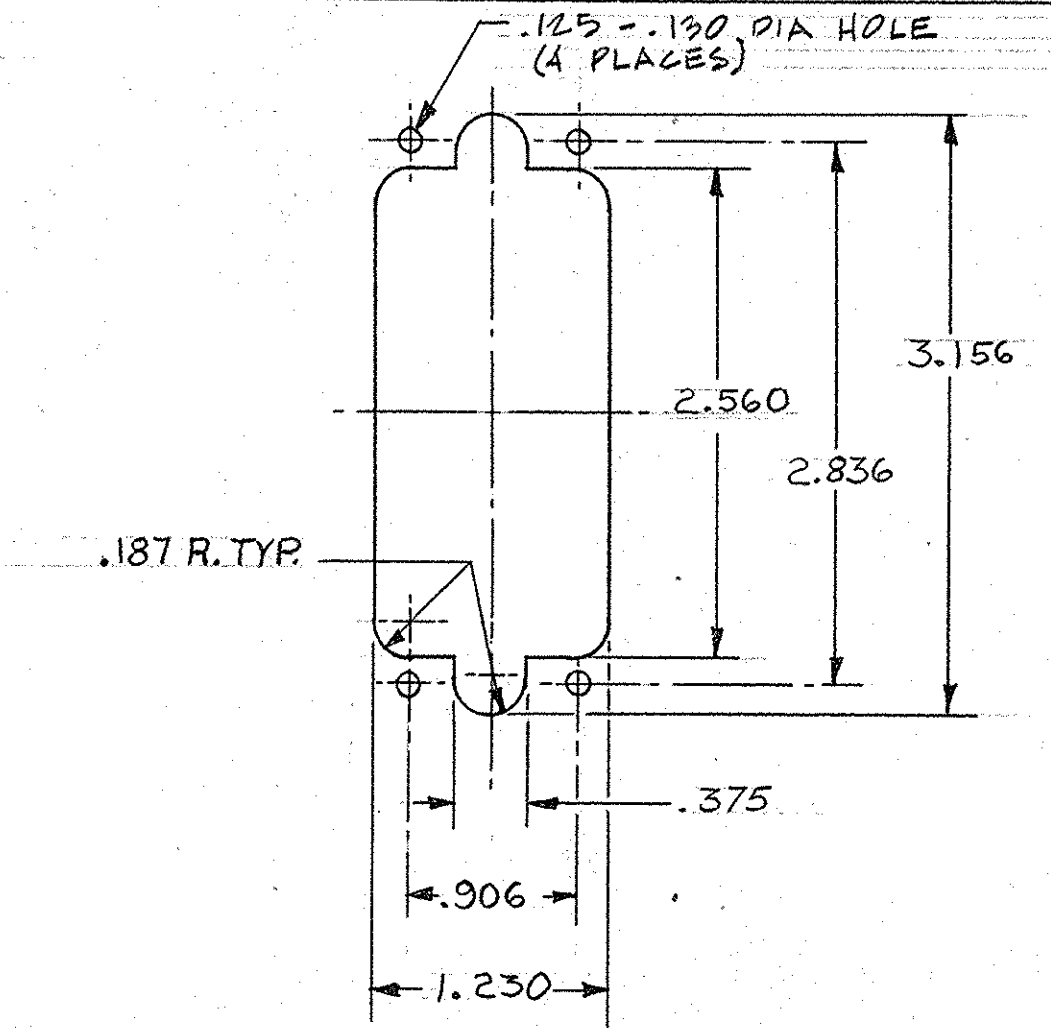
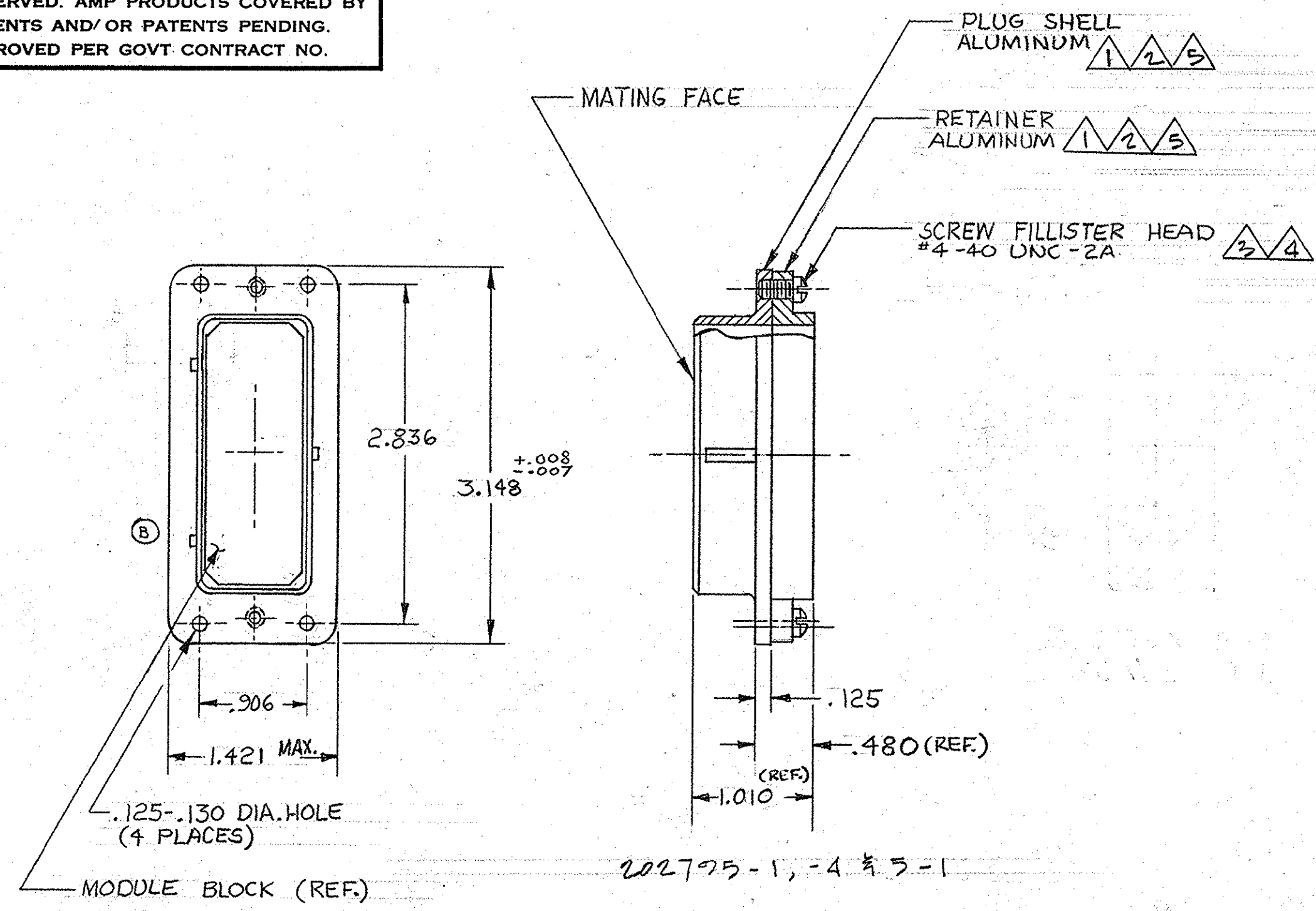

PANEL CUTOUT  
SCALE: 1-1

- ① ZINC PLATE PER ASTM-B-633 TYPE II .000200-.000400 THK CLASS 3 COLORLESS SUPPLEMENTARY CHROMATE.
- ② ELECTROLESS NICKEL PLATE PER SAE-AMS-C-2607A .000400-.000800 THK (NO INTENTIONAL ADDITIONS OF LEAD OR CADMIUM PER DFE STANDARD 230-700).
- ③ ZINC PLATED COLD ROLLED STEEL.
- ④ PASSIVATED STAINLESS STEEL.
- ⑤ CADMIUM PLATE PER QQ-P-416 .000200-.000400 THK.

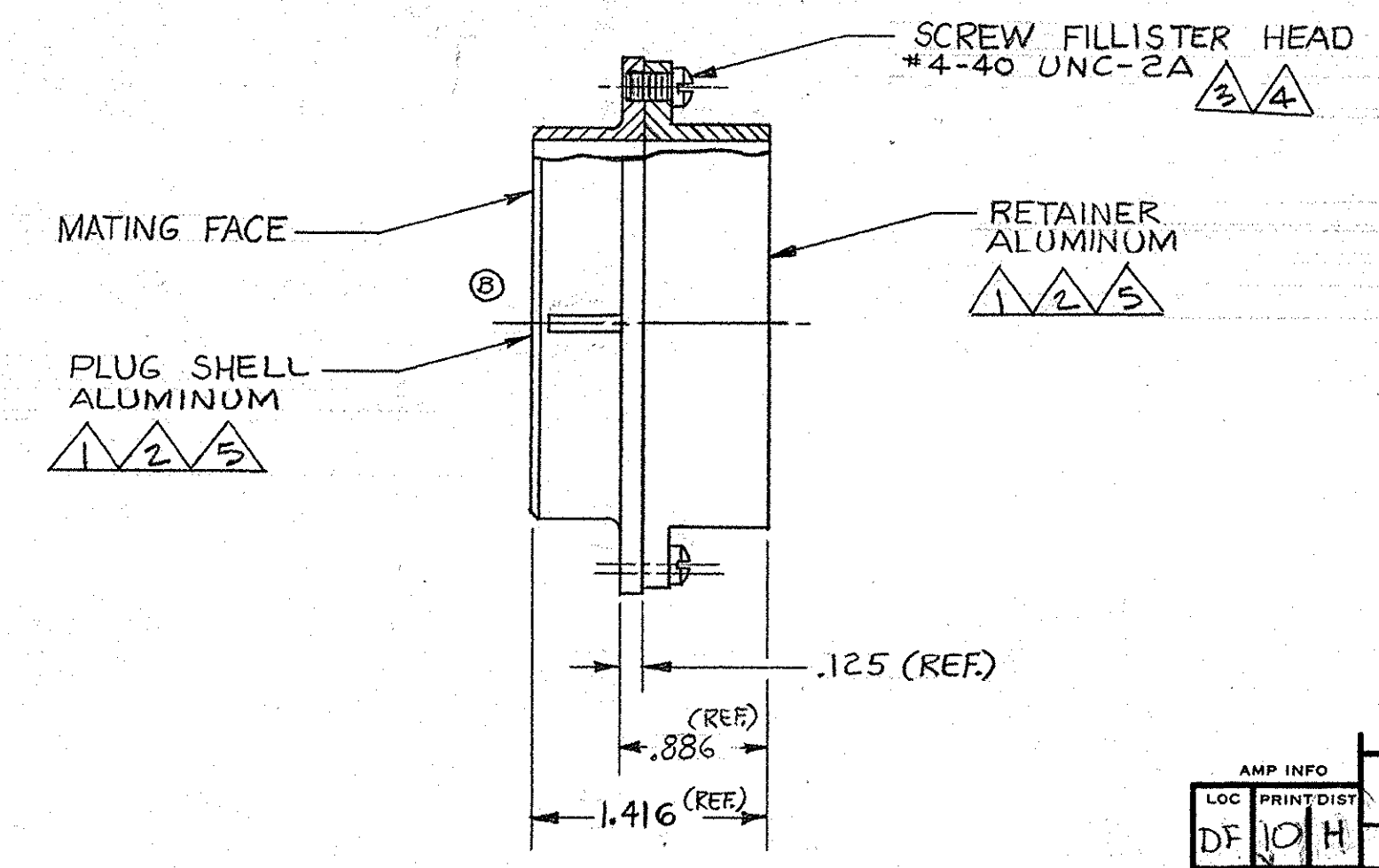

202795-2, -3 & 5-2

5-202795-2	FOR PINS	② ④	
5-202795-1	FOR SOCKETS	② ④	
202795-4	FOR SOCKETS	① ⑤	
202795-3	FOR PINS	① ③	OBSOLETE
202795-2	FOR PINS	① ③	SUPERSEDED BY 5-202795-2
202795-1	FOR SOCKETS	① ③	SUPERSEDED BY 5-202795-1
PART NO.	ASSY TYPE	FINISH	

AMP INFO		QTY REQD	NOMENCLATURE OR DESCRIPTION	PART OR IDENTIFYING NO	LIST OF MATERIALS OR PARTS LIST	
LOC	PRINT/DIST					
DF	10/H					
UNLESS OTHERWISE SPECIFIED DIMENSIONS ARE IN INCHES TOLERANCES ON			SIGNATURE		DATE	
FRACTIONS	DECIMALS	ANGLES	E. Benninger		10-12-65	
±	±	±	S. Steide		11-9-65	
			DSGN ENGR		11-9-65	
			MATERIAL		NAME	
			SEE CALL OUT		AMP INCORPORATED	
			HEAT TREAT		HARRISBURG, PENNSYLVANIA	
			—		PLUG ASSEMBLY, MODULE SERIES "G" (3 BLOCKS)	
			FINISH		CODE IDENT NO	
			SEE CALL OUT		00779	
			OTHER APPD		SIZE	
					D	
					NUMBER	
					202795	
					SCALE	
					1-1	
					WT	
					CALC	
					ACTUAL	
					SHEET	