

LOC	DIST	P	F	ZONE	LTR	DESCRIPTION	DATE	APPD
AF	50				F	REVISED PER 063A-0034-01	09FEB01	MF-KR

- 1 CONTINUOUS STRIP ON REELS WITH TERMINALS LOCATED ON 6.86±0.08 [.270±.003] CENTERS
- △2 SLOT ACCEPTS 0.18-0.23mm [#33-#31] AWG COPPER MAGNET WIRE. TWO WIRES OF THE SAME SIZE MAX PER SLOT
- △3 IDENTIFICATION NUMBER 4 FOR THE MAGNET WIRE SLOT SIZE
- △4 0.25[.010] MAX CARRIER CUT-OFF

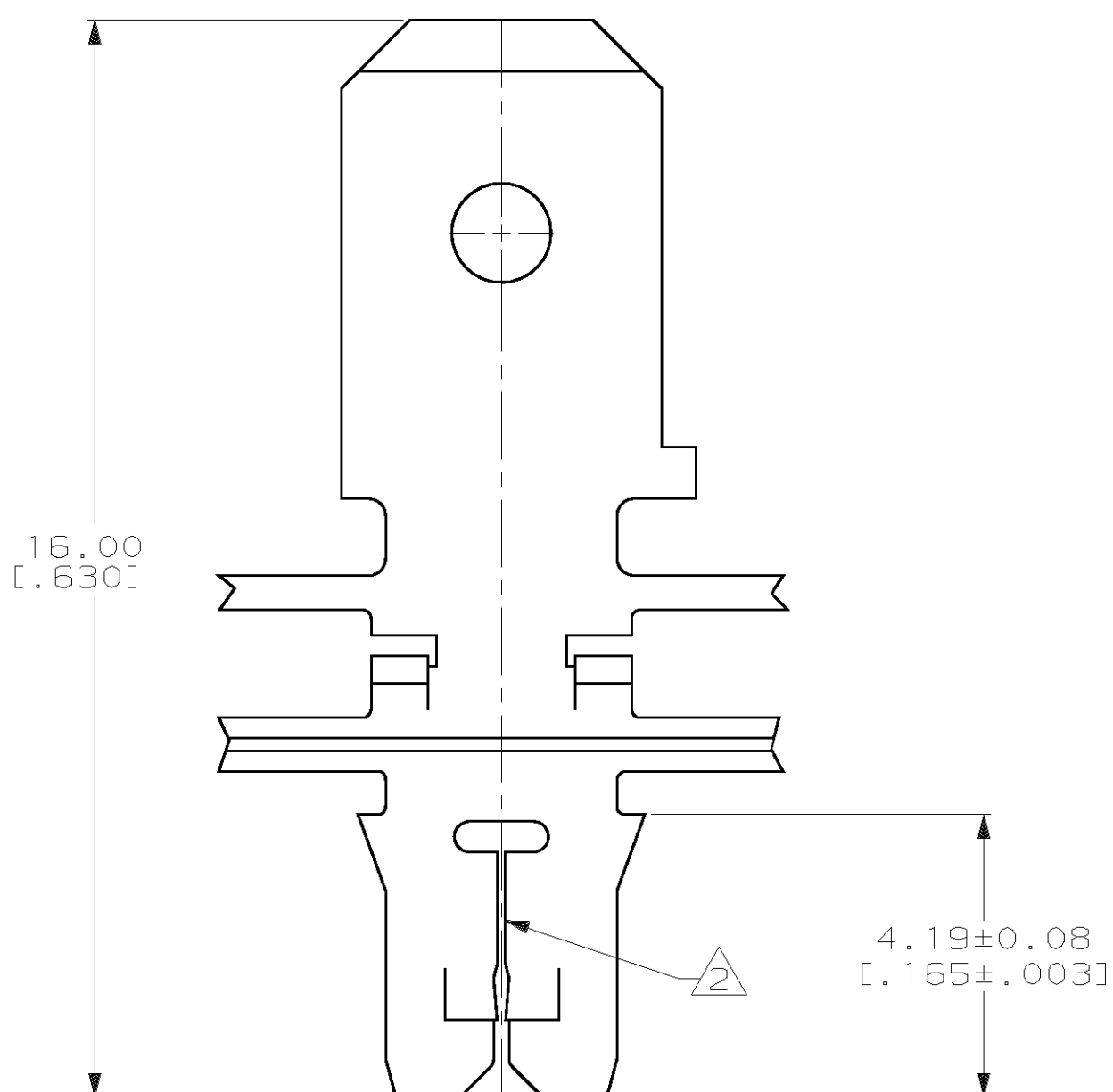
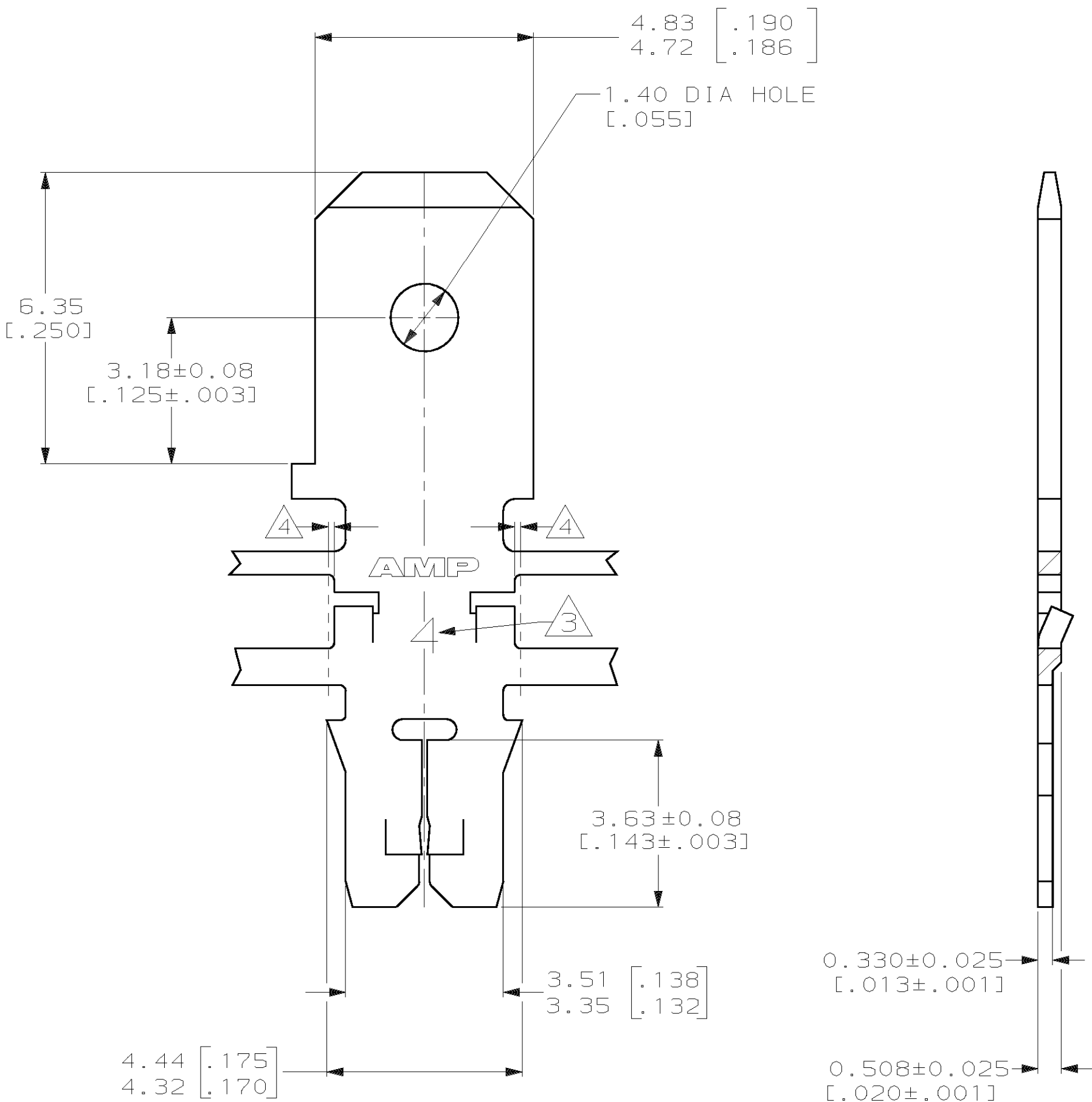

DO NOT SCALE PRINT. UNLESS SPECIFIED DIMENSIONS IN mm [INCHES] TOLERANCES ON : 2 PLC DEC ± 0.13 [.005] 3 PLC DEC ± - ANGLES ± -		DR 9-27-93 L.A.MAYER	082 PRE-MILLED BRASS		63710-2
MATERIAL SEE TABLE		CHK 9-27-93 M.S. FEHER	4M PRE-MILLED BRASS		63710-1
FINISH 0.002032 [.000080] MIN TIN		APPD 9-27-93 A.HUNT III	MATERIAL		PART NO
APPLICATION SPEC 114-2140		APPD 9-27-93 T.L.SHUTTER	AMP Incorporated Harrisburg, PA 17105-3608		
WEIGHT -		PRODUCT SPEC 108-1484	NAME TAB, 4.75 [.187] FASTON™ MAG-MATE™ Slim Line		
		SCALE 10:1	SIZE C	CAGE CODE 00779	DRAWING NO C=63710
			SHEET 1 OF 1		

THIS DRAWING IS A CONTROLLED DOCUMENT FOR AMP INCORPORATED. IT IS SUBJECT TO CHANGE AND THE CONTROLLING ENGINEERING ORGANIZATION SHOULD BE CONTACTED FOR THE LATEST REVISION.