

THIS DRAWING IS UNPUBLISHED. RELEASED FOR PUBLICATION 19  
© COPYRIGHT 19 BY AMP INCORPORATED, HARRISBURG, PA. ALL INTERNATIONAL RIGHTS RESERVED. AMP PRODUCTS MAY BE COVERED BY U.S. AND FOREIGN PATENTS AND/OR PATENTS PENDING.

REVISIONS					
P/F	ZONE	LTR	DESCRIPTION	DATE	APPROVED
W	REV	PER	ECO 09-015348 CT	8-09	DM
Y	ECO-10-002912	PY		3-10	DM

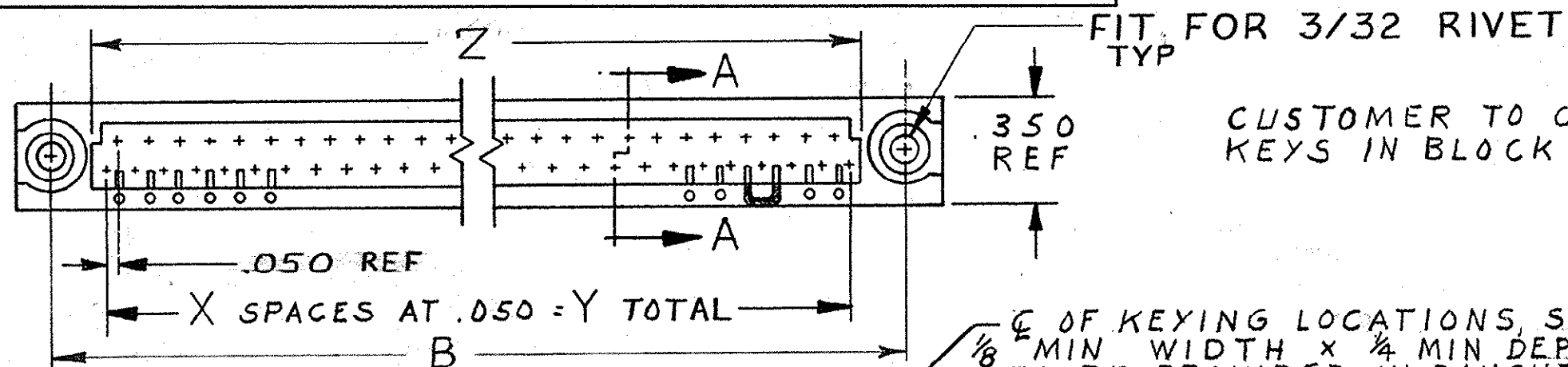

CUSTOMER TO CRIMP KEYS IN BLOCK AS REQD

E OF KEYING LOCATIONS, SLOT MIN WIDTH X 1/4 MIN DEPTH TO BE PROVIDED IN DAUGHTER BOARD BY CUSTOMER

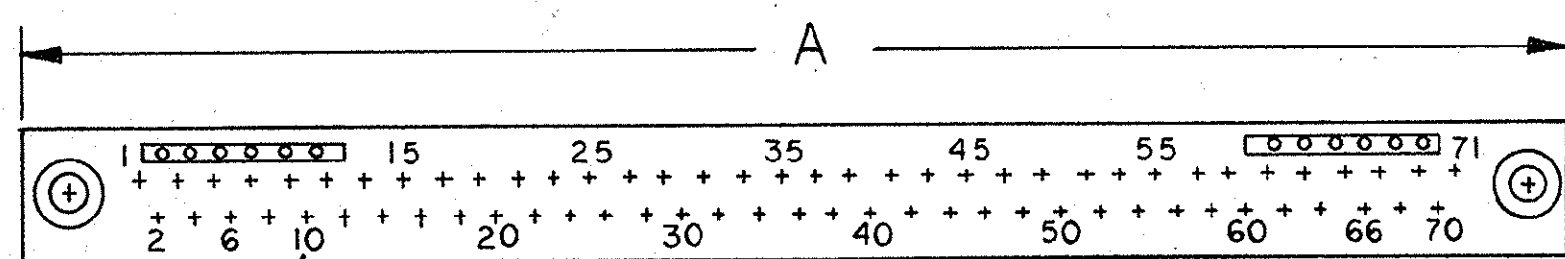
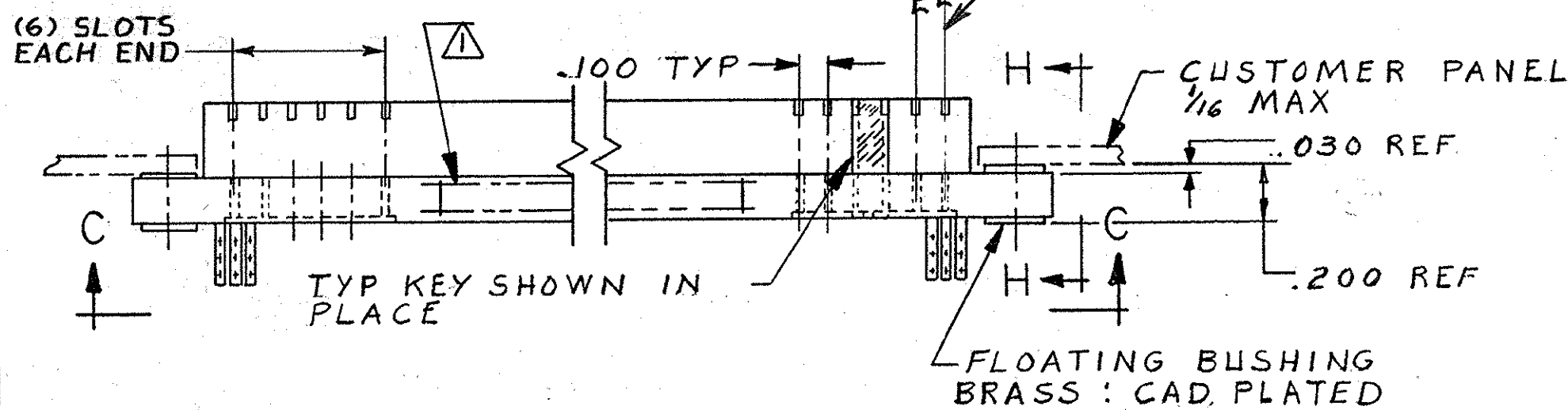

#1 AND THE LAST CONTACT PLUS CONTACT NUMBERS SHOWN MOLDED ON THIS FACE ONLY  
VIEW C-C FOR -1

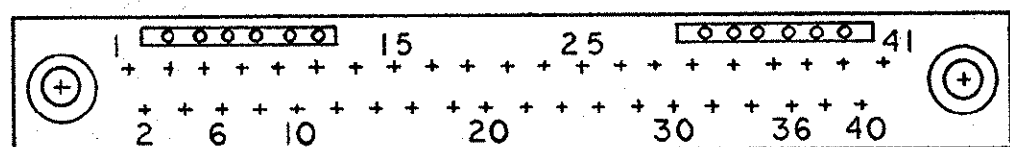

VIEW C-C FOR -2

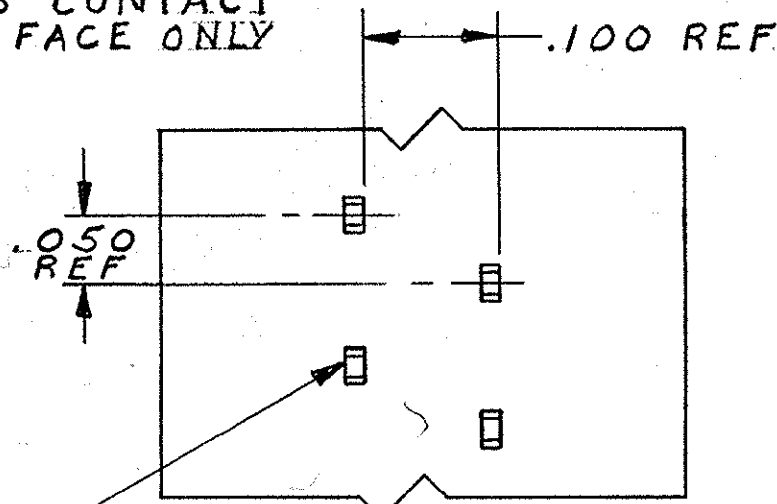
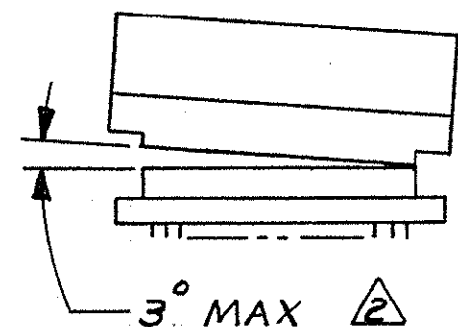

TYPE III  
VIEW E-E

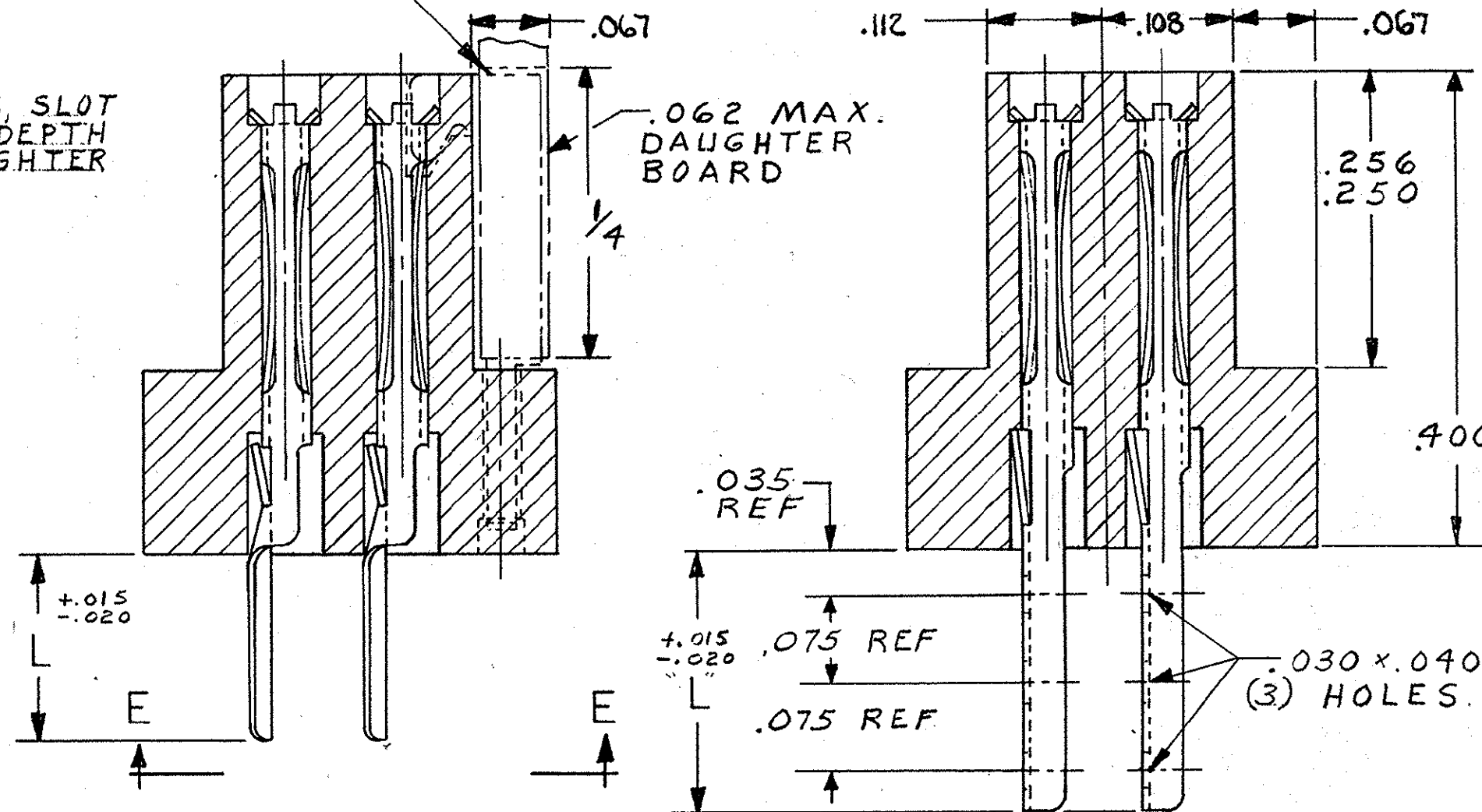

SECT A-A  
SCALE 8:1  
TYPE I

SECT A-A  
SCALE 8:1 TYPE II

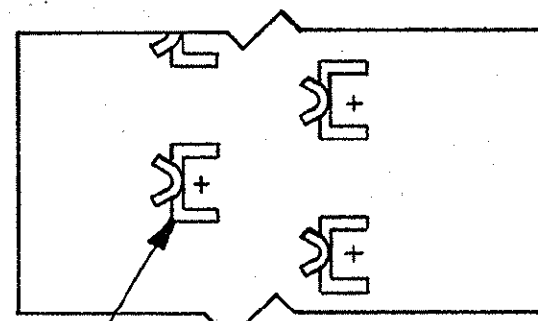

PC BOARD SOLDER TAIL ENTERS .022 MIN DIA HOLE

TYPE I

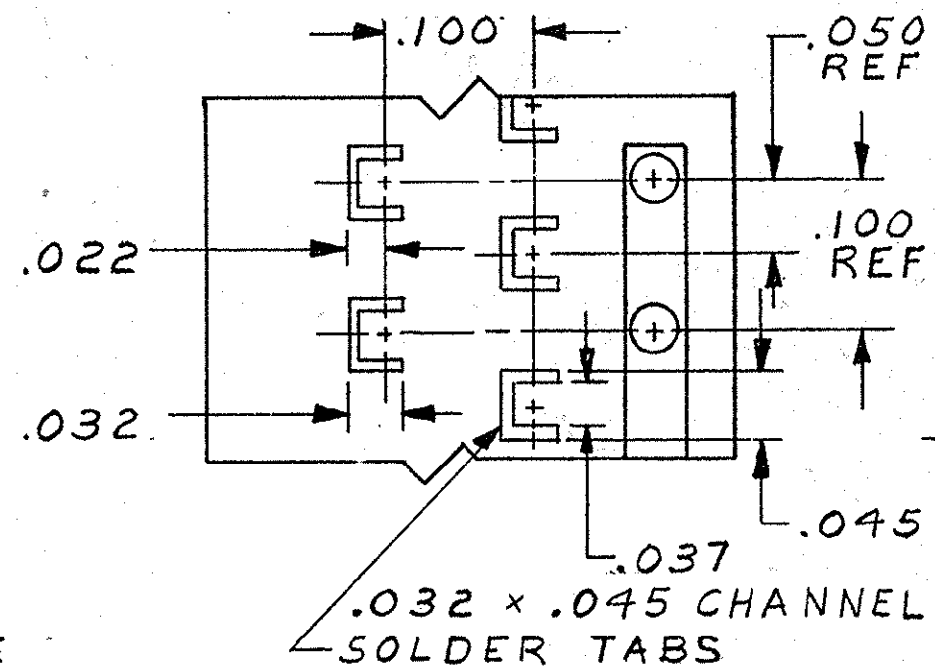

TYPE II

UNLESS OTHERWISE SPECIFIED DIMENSIONS ARE IN INCHES. TOLERANCES ON: DECIMALS ±.010 ANGLES		CONTRACT NO DR <i>W. Lenz</i> 12-16-82 CHK 12-22-82 EAM APPD <i>E. A. McLaughlin</i> 12-22-82 APPD <i>E. T. Parsons</i> 12-22-82 DSGN APPD OTHER APPD		AMP   AMP INCORPORATED Harrisburg, Pa. 17105	
MATERIAL CONTACTS: $\Delta$ HSG: DIALLYL PHTHALATE		NAME RECEPTACLE ASSEMBLY, BOX, 1000 SERIES, STAGGERED		SIZE FSCM NO DRAWING NO REV C 00779 202932 Y	
FINISH CONTACTS: SEE TABLE		SCALE 2:1		SHT 1 of 4	

THIS DRAWING IS UNPUBLISHED. RELEASED FOR PUBLICATION, 19  
 © COPYRIGHT 19 BY AMP INCORPORATED, HARRISBURG, PA. ALL INTERNATIONAL RIGHTS RESERVED. AMP PRODUCTS MAY BE COVERED BY U.S. AND FOREIGN PATENTS AND/OR PATENTS PENDING.

REVISIONS					
P	F	ZONE/LTR	DESCRIPTION	DATE	APPROVED

SEE SHEET #1

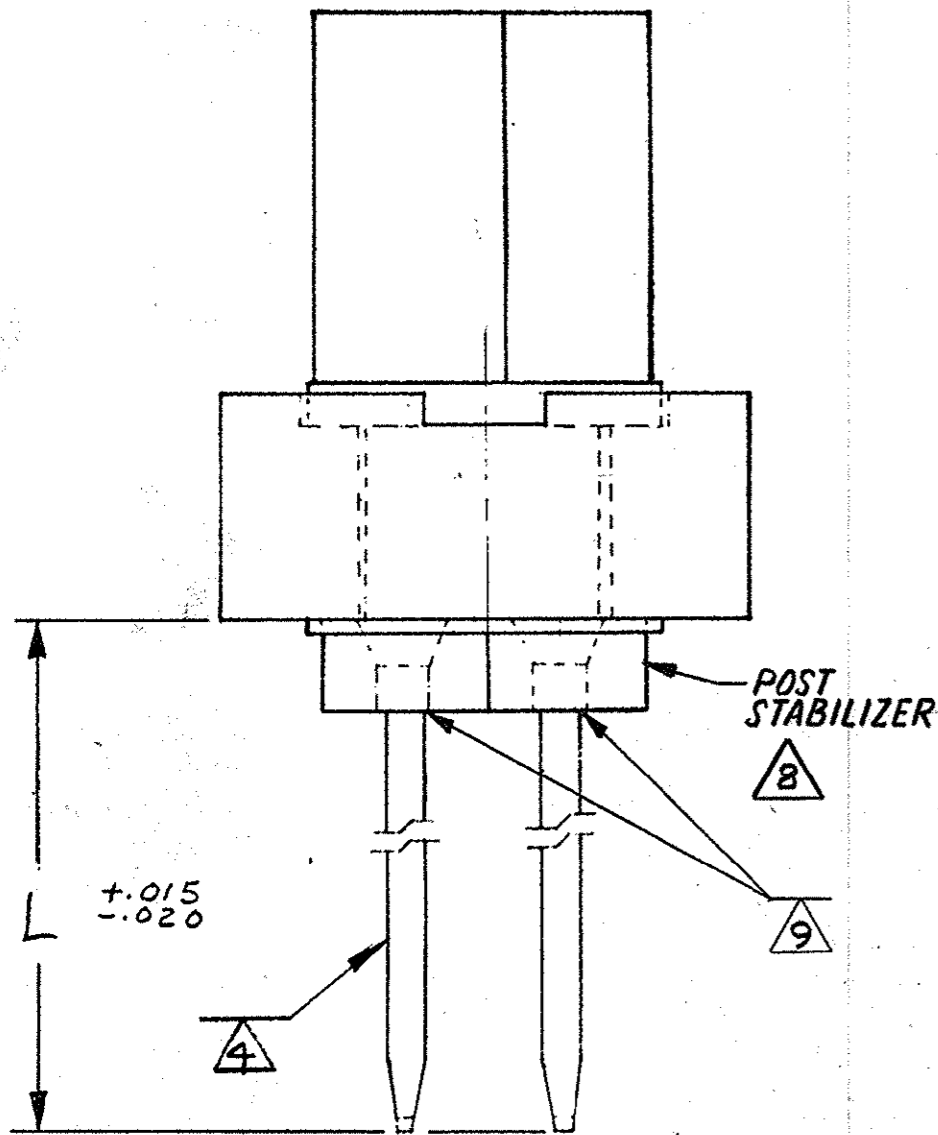

VIEW H-H  
SCALE 8:1

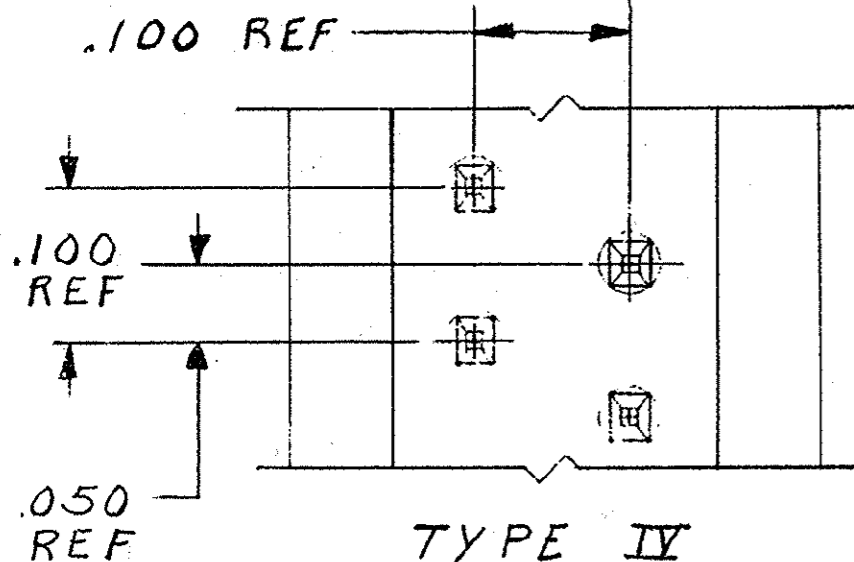

.022 x .027 POST  
 (.034 MAX. DIAGONAL),  
 8 TURNS # 30 WIRE  
 PER WRAP

OBS																		
OBS	7	2-202932-7	71	II	.220	SAME AS -1 EXCEPT FINISH.												
OBS	7	2-202932-6	41	II	.220	SAME AS -2 EXCEPT FINISH.												
OBS	6	2-202932-5	71	IV	.725	SAME AS -1 EXC. FINISH; VIEW H-H APPLIES												
OBS	6	2-202932-4	41	IV	.725	SAME AS -2 EXC. FINISH ; VIEW H-H APPLIES												
OBS		2-202932-3																
OBS		2-202932-2																
OBS	x 4	2-202932-1	71	III	.125	SAME AS -1 EXCEPT CONTACT & STAMP CUST. P/N 201C 8566-01-021.												
OBS	6	2-202932-0	41	IV	.405	SAME AS -2 EXCEPT CONTACT & STABILIZER - SEE VIEW H-H												
OBS	x 4	1-202932-9	71	IV	.565	SAME AS -1 EXCEPT CONTACT & STABILIZER - SEE VIEW H-H												
OBS	x	1-202932-8	41	I	.156	SAME AS -6 EXCEPT ADDITIONAL STAMPING 00779 (1J109-1)												
OBS		1-202932-7	71	IV	.405	SAME AS -1 EXCEPT CONTACT - SEE VIEW H-H												
OBS	x	1-202932-6	41	IV	.725	SAME AS -2 EXCEPT CONTACT - SEE VIEW H-H												
OBS		1-202932-5	71	IV	.725	SAME AS -1 EXCEPT CONTACT - SEE VIEW H-H												
OBS	x	1-202932-4	41	III	.325	SAME AS -2 EXCEPT CONTACT - SEE VIEW E-E												
OBS	4	1- -3	71	III	.325	SAME AS -1 EXCEPT CONTACT - SEE VIEW E-E												
OBS	x 7	1- -2	71	III	.185	SAME AS -1 EXCEPT CONTACT - SEE VIEW E-E												
OBS	x 4	1- -1	41	I	.156	SAME AS -6 EXCEPT WITHOUT BUSH & WITH .092 DIA HOLE												
OBS		1- -0	71	I	.156	SAME AS -5 EXCEPT WITHOUT BUSH & WITH .092 DIA HOLE												
OBS	x	-9	41	II	.220	SAME AS -2 EXCEPT SST. BUSHINGS - PASSIVATED.												
OBS	x	-8	71	II	.220	SAME AS -1 EXCEPT SST. BUSHINGS - PASSIVATED.												
OBS		-7	71	I	.156	SAME AS -5 EXCEPT FLOATING BUSHINGS REMOVED.												
		-6	41	I	.156	SAME AS -2 EXCEPT CONTACT - SEE SECTION A-A												
		-5	71	I	.156	SAME AS -1 EXCEPT CONTACT - SEE SECTION A-A												
OBS		-4	41	II	.220	SAME AS -2 EXCEPT STAMP CUST. NO. CMC 410-500/2.												
OBS		-3	71	II	.220	SAME AS -1 EXCEPT STAMP CUST. NO. CMC 410-500/1												
		-2	41	II	.220	2.615	2.370	40	2.000	2.125								
	4	202932-1	71	II	.220	4.115	3.870	70	3.500	3.625								
FINISH		ASSY NO.	NO POS	TYPE	L	A	B	X	Y	Z								

UNLESS OTHERWISE SPECIFIED DIMENSIONS ARE IN INCHES. TOLERANCES ON: DECIMALS $\pm .010$ ANGLES		CONTRACT NO DR <i>R.P. Lenzert</i> 12-16-82 CHK 12-22-82 EAM APPD <i>E.H. McLaughlin</i> 12-22-82 APPD <i>E.T. Parsons</i>		AMP INCORPORATED Harrisburg, Pa. 17105	
MATERIAL CONTACTS: $\Delta$ HSG: DIALYL PHTHALATE		DSGN APPD		NAME RECEPTACLE ASSEMBLY, BOX, 1000 SERIES, STAGGERED	
FINISH CONTACTS: SEE TABLE		OTHER APPD		SIZE C	FSCM NO 00779
				DRAWING NO 202932	REV Y
				SCALE	SHEET 2 of 4

THIS DRAWING IS UNPUBLISHED. RELEASED FOR PUBLICATION, 19  
 © COPYRIGHT 19 BY AMP INCORPORATED, HARRISBURG, PA. ALL INTERNATIONAL RIGHTS RESERVED. AMP PRODUCTS MAY BE COVERED BY U.S. AND FOREIGN PATENTS AND/OR PATENTS PENDING.

REVISIONS				DATE	APPROVED
P	F	ZONE	LTR	DESCRIPTION	

SEE SHEET #1

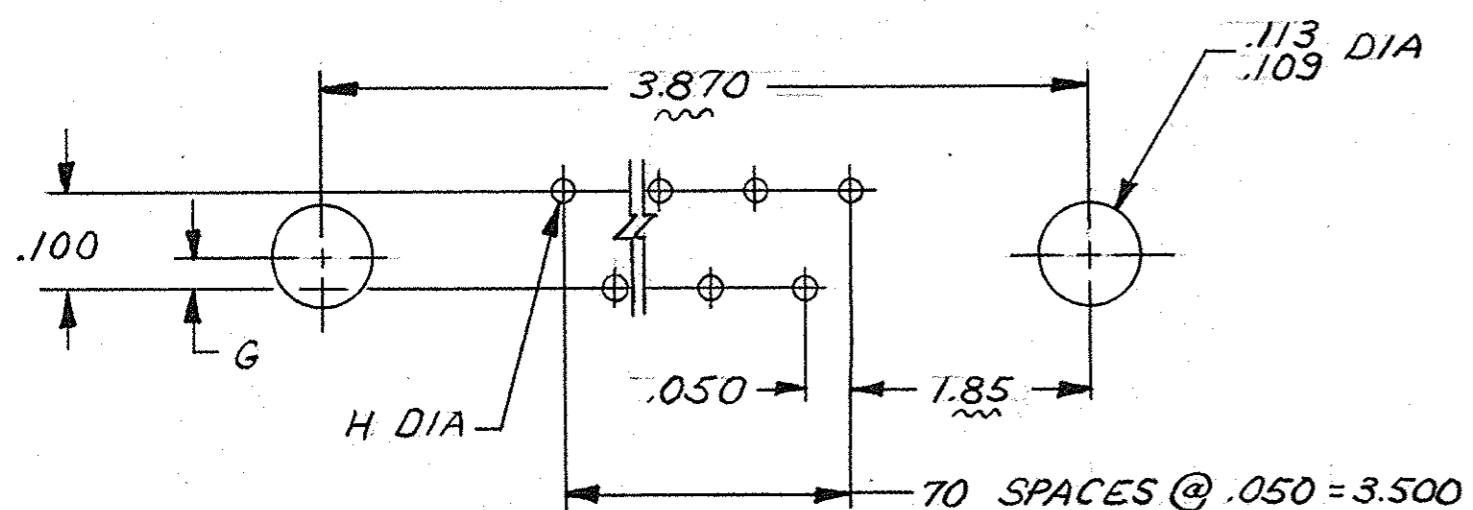

71-POSITION RECEPTACLE ASSEMBLY

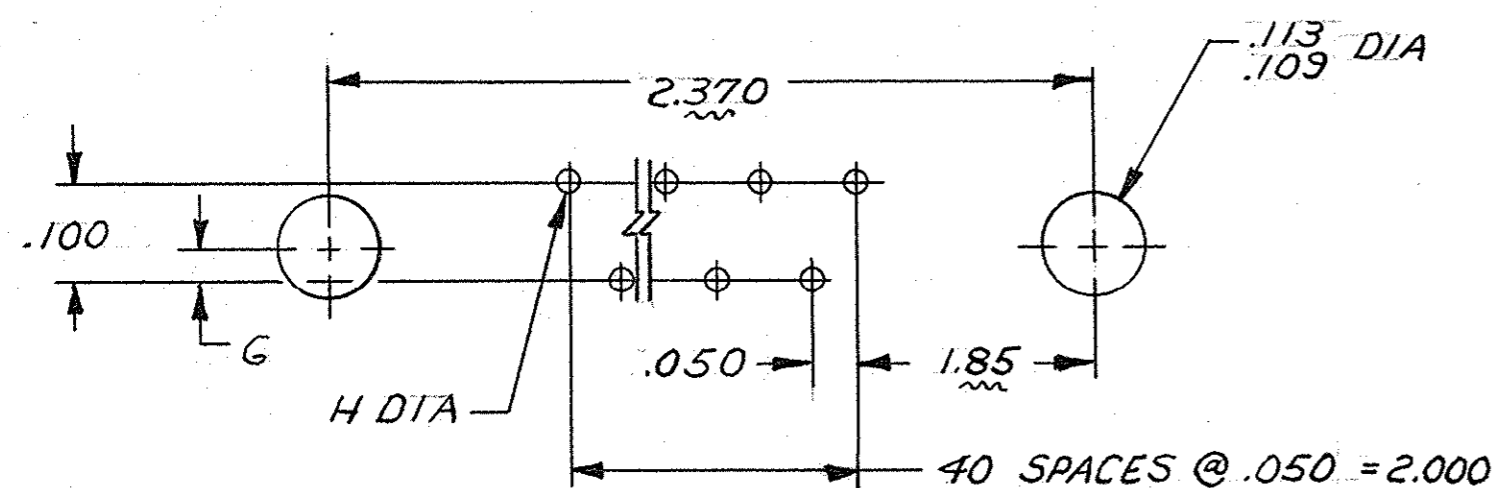

41-POSITION RECEPTACLE ASSEMBLY

CONTACT TYPE	DIMENSIONS	DIMENSIONS	
		G	H
TYPE III .010 X .020 POST		.050	.030
TYPE I FLOW SOLDER		.025	.025
TYPE IV .022 X .027 POST		.050	.050

RECOMMENDED PC BOARD LAYOUT

UNLESS OTHERWISE SPECIFIED DIMENSIONS ARE IN INCHES. TOLERANCES ON: DECIMALS ± .010 ANGLES ±		CONTRACT NO DR 2-5-85 Brenda H. Martin		PART NO	
MATERIAL		CHK James P. Scholz 2-6-85		NAME RECEPTACLE ASSEMBLY, BOX, 1000-SERIES, STAGGERED	
FINISH		APPD James P. Scholz 2-6-85		DRAWING NO 202932	
		APPD J. J. [Signature] 2/2/85		REV Y	
		DSGN APPD		SIZE C FSCM NO 00779	
		OTHER APPD		SHEET 3 of 4	
		SCALE 5:1			

202932

THIS DRAWING IS UNPUBLISHED. RELEASED FOR PUBLICATION, 19 .  
 © COPYRIGHT 19 BY AMP INCORPORATED, HARRISBURG, PA. ALL INTERNATIONAL RIGHTS RESERVED. AMP PRODUCTS MAY BE COVERED BY U.S. AND FOREIGN PATENTS AND/OR PATENTS PENDING.

REVISIONS					
P	F	ZONE	DESCRIPTION	DATE	APPROVED
✓	✓		SEE SHEET #1		

- 1 AMP, PART NO. & DATE CODE MARKED, THIS APPROX AREA ON OPPOSITE SIDE. CUST PART NO. INCLUDED WHEN REQUIRED.
- 2 THESE CONNECTORS ARE TO BE USED WITH CARD GUIDES ONLY. PERMISSIBLE CONNECTOR ENTRY ANGLE IS 3° MAX.
- 3. PART NOS MEETING ALL APPLICABLE REQUIREMENTS OF MIL-C-55302 INCLUDE: 2--1, 2--2, 2--3.
- 4 FINISH: .000030 GOLD IN CONTACT AREA, TIN-LEAD ON TAILS, ALL OVER NICKEL UNDERPLATE.
- 5 CONTACT MAT'L: BERYLLIUM COPPER OR COPPER-NICKEL-SILICONE
- 6 FINISH: .000050 GOLD OVER .000050-.000100 NICKEL.
- 7 FINISH: .000050 GOLD ON CONTACT AREA, TIN-LEAD ON TAILS ALL OVER NICKEL UNDERPLATE.
- 8 MATL: GLASS FILLED, FLAME RETARDANT THERMOPLASTIC (SEO RATED) COLOR-BLACK. NO STABILIZER USED ON PART NUMBER(S): 1-202932-9.
- 9 EPOXY ADDED TO AREA WHERE THE CONTACT POSTS EMERGE FROM THE STABILIZER TO INSURE POST TRUE POSITION, -15, -16, -17, -20, -24, & -25 ONLY.

202932

UNLESS OTHERWISE SPECIFIED DIMENSIONS ARE IN INCHES. TOLERANCES ON: DECIMALS ± — ANGLES ± —		CONTRACT NO DR <i>D. Binkler</i> 7-02-85		AMP INCORPORATED Harrisburg, Pa. 17105	
MATERIAL		CHK <i>James P. Scholz</i> 7-2-85 APPD <i>James P. Scholz</i> 7-2-85 APPD <i>D. Binkler</i> 7/2/85		NAME RCPT ASSY, BOX, 1000 SERIES, STAGGERED	
FINISH		DSGN APPD		SIZE C	FSCM NO 00779
		OTHER APPD		DRAWING NO 202932	REV Y
				SCALE	SHEET 4 of 4