

PART NUMBER	REV	FIRST USED
466081-1	5	854400-1
466081-2	5	565435-5

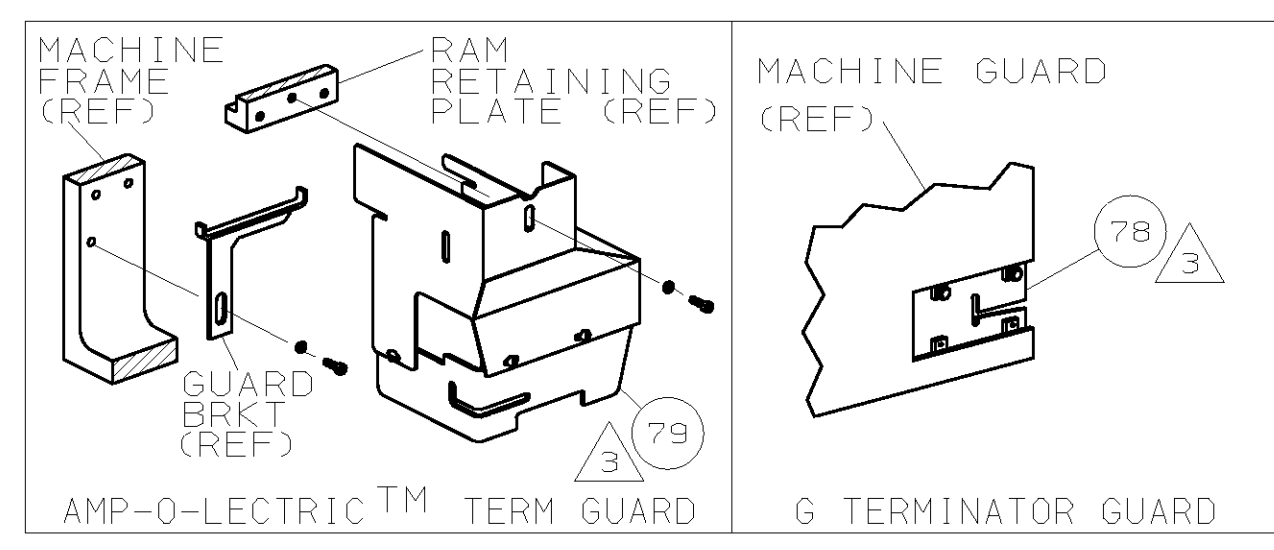

TERMINAL NAME: Ø.180 SHUR PLUG		CRIMPING DATA			
60793	62739	PAD LTR	CRIMP HEIGHT	WIRE SIZE	
		A	.078 ±.002 [1.88 ±0.05mm]	14	
		B	.069 ±.002 [1.65 ±0.05mm]	16	
		C	.063 ±.002 [1.5 ±0.05mm]	18	
		D	NOT	USED	
		CRIMP	SIZE	TYPE	RANGE
		WIRE	.110 [2.79mm]	F	18-14
		INSUL	.140 [3.56mm]	F	.090-.125
WIRE STRIP LENGTH	TERM APPL SPEC	FEED	APPL INSTRUCTION	SET UP GAGE	LAYOUT
.188	114-2017	.805	408-8039	458638-1	87

LEADMAKER & BENCH MODEL G		MECH POST FEED				
REF	REF	-	A	22594-8	NUT, HEX	70
REF	REF	-	B	240628-1	PLATE, ADJ	69
REF	REF	-	B	240626-1	SHAFT, PIVOT	68
REF	REF	-	B	240633-1	BUSHING	67
REF	REF	-	A	455680-1	LEVER, INTERMEDIATE	66
REF	REF	-	B	240629-1	BLOCK, PIVOT	65
REF	REF	-	A	240632-2	SCR, ADJ	64
REF	REF	-	B	240659-3	PIN, CAM ROLLER	63
REF	REF	-	B	240658-1	CAM, ROLLER	62
REF	REF	-	B	454398-1	ROD, FEED	61

THIS DRAWING IS A CONTROLLED DOCUMENT.

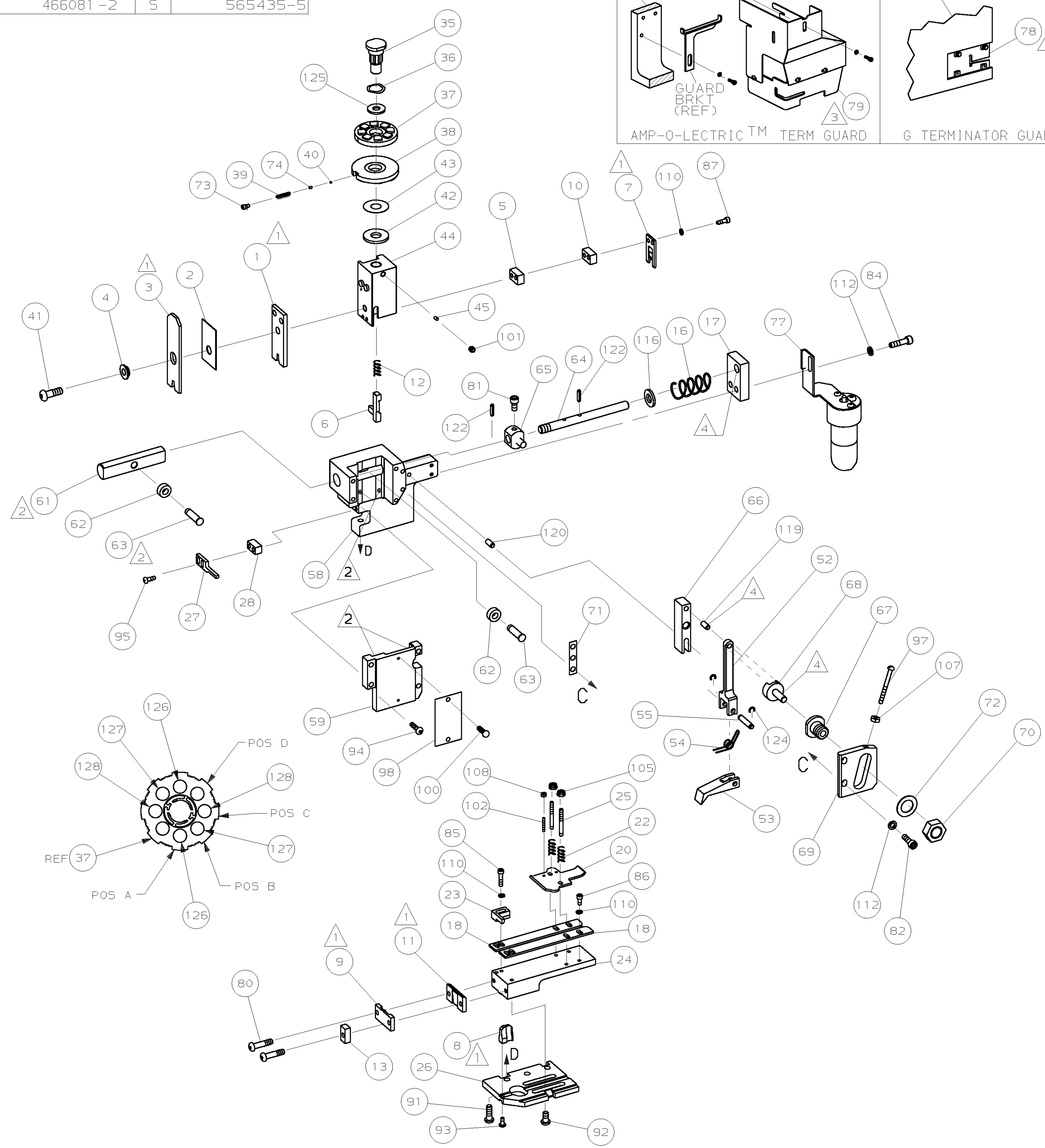

QTY	REF	REV	TERMINAL NAME	DESCRIPTION	ITEM NO	
2	2	-	C	9-354778-5 PIN, WIRE DISC (.2970)C	129	
2	2	-	C	8-354778-3 PIN, WIRE DISC (.2910)B	127	
2	2	-	C	6-354778-5 PIN, WIRE DISC (.2820)A	126	
1	1	-	A	986950-1 WASHER, FLAT PRECISION	125	
REF	REF	-	A	21045-3 RING, RET "C" (Ø.187)FD PIN	124	
REF	REF	-	A	5-21028-1 PIN, STD SPRING (Ø.12)FD ADJ ROD	122	
REF	REF	-	A	1-21030-7 PIN, DOWEL (Ø.187x1.50)H5G	120	
REF	REF	-	A	1-21030-1 PIN, DOWEL (Ø.187x.50)LEVER	119	
REF	REF	-	A	21899-4 WASHER, FLAT (Ø5/16) SCR ADJ	116	
REF	REF	-	A	21024-5 WASHER, LOCK (NO.10)FD ROD GDE	112	
7	7	-	A	21024-4 WASHER, LOCK (NO.8)SHEAR BL	110	
2	2	-	A	21018-4 NUT, HEX (4-40)DRAG	108	
REF	REF	-	A	21018-5 NUT, HEX (6-32)FD ADJ PL	107	
2	2	-	A	21022-2 NUT, HEX 5L (8-32)DRAG STUD	105	
2	2	-	A	2-21006-6 SCR, SKT SET (4-40x.62)DRAG	102	
1	1	-	A	21009-2 SCR, SKT SET (1/4-20x.25)RAM	101	
2	2	-	A	21017-2 SCR, DRIVE (#2x.19) ID PLATE	100	
1	1	-	A	1-21002-7 SCR, BHC (6-32x.38)CAM	99	
1	1	-	B	461264-1 PLATE, IDENTIFICATION	98	
REF	REF	-	A	6-23715-5 SCR, PAN HD (6-32x1.50)FEED ADJ	97	
2	2	-	A	2-21002-2 SCR, BHC (8-32x.50)STRIPPER	95	
REF	REF	-	A	2-21002-9 SCR, BHC (10-32x.75)H5G CAP	94	
1	1	-	A	22733-8 SCR, BHC (8-32x.38 LW)ANVIL	93	
4	4	-	A	3-21002-3 SCR, BHC (1/4-20x.50)ST 6D PL	92	
REF	REF	-	A	2-22733-8 SCR, BHC (1/4-20x.62)BASE PL	91	
					90	
					89	
					88	
2	2	-	A	2-21000-7 SCR, 5HC (8-32x.50)SLUG BLADE	87	
3	3	-	A	2-21000-6 SCR, 5HC (8-32x.38)STRIP GUIDE	86	
2	2	-	A	2-21000-9 SCR, 5HC (8-32x.75)R STRIP GUIDE	85	
REF	REF	-	A	3-21000-7 SCR, 5HC (10-32x.75)FEED ROD GDE	84	
REF	REF	-	A	3-21000-6 SCR, 5HC (10-32x.62)FEED ADJ PL	83	
REF	REF	-	A	3-21000-4 SCR, 5HC (10-32x.38)PIVOT BLOCK	81	
2	2	-	A	3-21002-0 SCR, BHC (10-32x.88)SHEAR PL	80	
REF	REF	-	A	455745-1 GUARD, WINDOW	79	
-	REF	-	A	679532-1 INSERT, GUARD	78	
1	-	-	C	465184-9 LUBRICATOR ASSY	77	
					76	
					75	
1	1	-	A	690603-1 SPRING, ASSIST	74	
1	1	-	A	23030-1 SCR, SKT CAP (6-32x.25)CP DSC	73	
REF	REF	-	A	458109-1 WASHER, FLAT (SPECIAL)	72	
REF	REF	-	A	690517-1 SPACER	71	
-2	-1	U/M	DWG SIZE	PART NO	DESCRIPTION	ITEM NO
QTY REOD PER ASSY						

QTY	REF	REV	TERMINAL NAME	DESCRIPTION	ITEM NO
1	1	-	B	690501-3 CAM, POST FEED 1 1/8 ST	48
-	1	-	B	690501-4 CAM, POST-FEED 1 5/8 ST	47
					46
1	1	-	A	690191-1 PLUG, NYLON	45
1	1	-	C	455674-1 RAM	44
1	1	-	A	690125-1 WASHER, LAMINATED	43
1	1	-	A	690124-1 WASHER, RAM	42
1	1	-	A	7-21002-9 BOLT, CRIMPER (5/16-24x1.00)	41
1	1	-	A	23241-6 BALL, STEEL	40
1	1	-	A	690170-1 SPRING, COMPRESSION	39
1	1	-	C	690142-1 DISC, INSULATION	38
1	1	-	D	354777-1 WIRE DISC, PLASTIC	37
1	1	-	A	22480-5 WASHER, SPRING	36
1	1	-	B	690212-1 POST, RAM	35
					34
					33
1	1	-	D	458980-2 APPLICATOR, BASIC (SUB ASSY)	32
					31
					30
					29
1	1	-	B	3-690451-2 SPACER, STRIPPER	28
1	1	-	A	240639-1 STRIPPER	27
REF	REF	-	C	455676-1 PLATE, BASE	26
2	2	-	A	22354-8 DRAG, STUD	25
1	1	-	B	455678-3 PLATE, STRIP GUIDE	24
1	1	-	C	240825-1 PLATE, STRIP HOLD DOWN	23
2	2	-	A	4-22281-1 SPRING, DRAG	22
					21
1	1	-	A	454177-1 DRAG, STOCK	20
					19
2	2	-	C	454204-4 GUIDE, STRIP (FRONT)	18
REF	REF	-	A	454178-1 GUIDE, FEED ROD	17
REF	REF	-	A	4-22284-9 SPRING, FEED RETURN	16
					15
					14
1	1	-	C	690481-2 SPACER, HOLD DOWN	13
1	1	-	A	23846-1 SPRING, HOLD DOWN	12
1	1	-	B	240833-4 PLATE, REAR SHEAR	11
1	1	-	C	5-240641-0 SPACER, SLUG BLADE	10
1	1	-	B	2-690496-1 PLATE, FRONT SHEAR	9
1	1	-	D	4-240693-2 ANVIL	8
1	1	-	B	1-690474-0 BLADE, SLUG	7
1	1	-	D	3-455892-0 HOLD DOWN, TERMINAL	6
1	1	-	C	6-240641-7 SPACER, SLUG BLADE	5
1	1	-	B	238009-1 SPACER, BLOCK CRIMPER	4
1	1	-	C	1-456134-4 CRIMPER, INSULATION	3
1	1	-	B	455888-1 SPACER, CRIMPER	2
1	1	-	C	456408-3 CRIMPER, WIRE	1

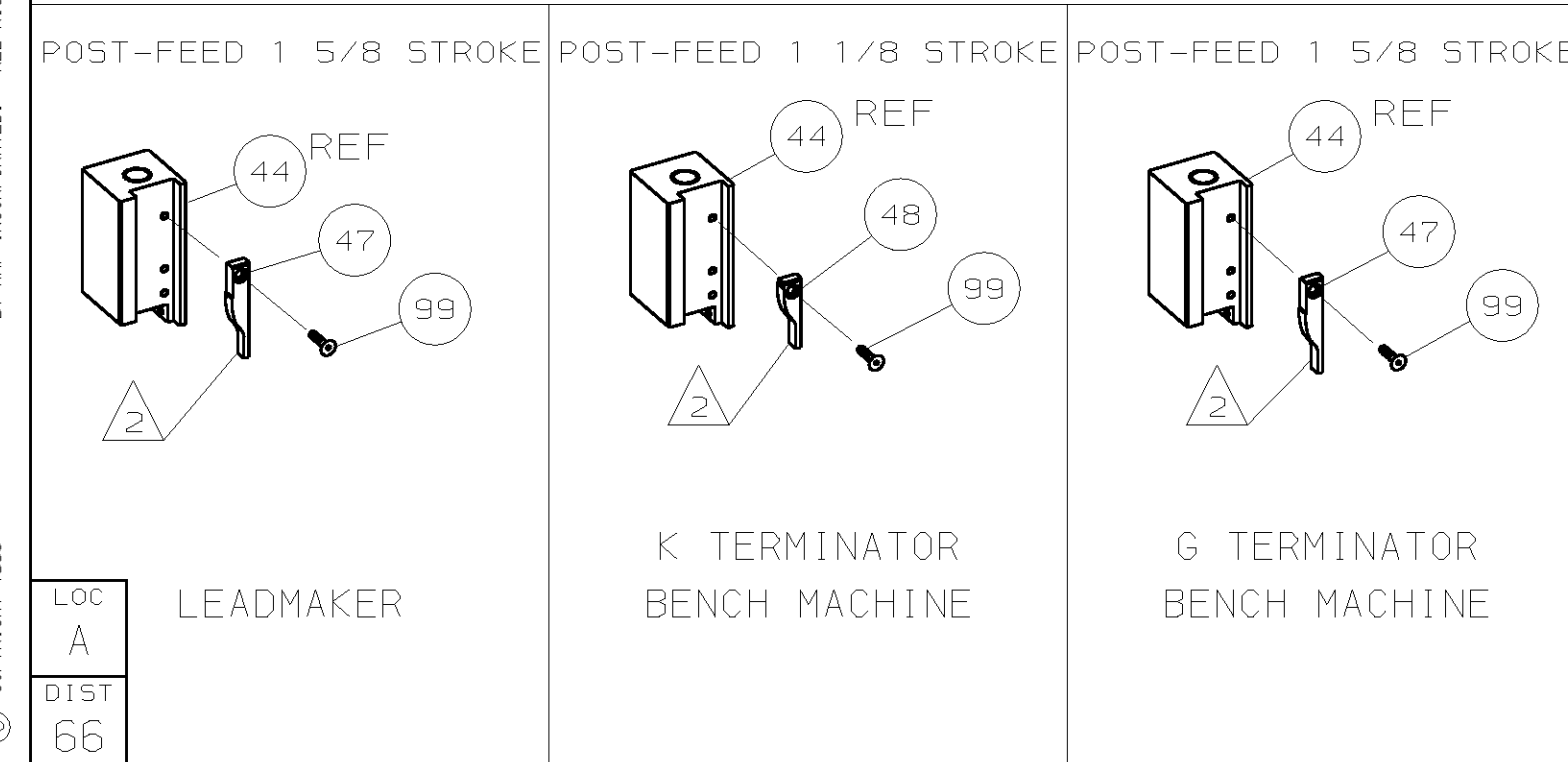

- 1 RECOMMENDED SPARE PARTS.
- 2 GREASE LIGHTLY.
- 3 GUARD MUST BE IN PLACE WHEN OPERATING APPLICATOR IN A BENCH MACHINE.
- 4 LUBRICATE DAILY USING NO. 20 MACHINE OIL.
- 5. ITEMS WITH QTY OF REF SPECIFIED (EXCEPT ITEMS 78 AND 79) ARE USED ON ITEM 32.
- 6 ITEM 78 USED WITH G TERMINATOR ONLY.
- 7 LUBRICATION REQUIRED WITH NICKEL PLATED TERMINALS.