

NOTES: (b)

1. FOR WAVESOLDERING (SOLDER BATH TEMPERATURE 240°C FOR 5 SEC. AND SOLDER PREHEAT 120°C FOR 120 SEC.)
2. METALSHELLS: COPPER ALLOY; min. 315µm TIN over 40-80µm NICKEL
3. INSULATORS: PBT GF UL 94 V-0, BLACK
4. SIGNAL CONTACTS: COPPER ALLOY, PLATING (SEE PART NO.)
  - PLEASE ADD A for GOLD FLASH over NICKEL (PREFERRED TYPE)
  - PLEASE ADD B for 20µm HARD GOLD over min. 50µm NICKEL
  - PLEASE ADD C for 30µm HARD GOLD over min. 50µm NICKEL
5. METAL BRACKETS: ZINC DIE CAST; 300µm COPPER/40-120µm NICKEL/120-200µm TIN
6. THREADED INSERTS: COPPER ALLOY; min. 200µm TIN over 80µm NICKEL
7. COLLARS: COPPER ALLOY; NICKEL PLATED
8. HEXLOCKING SCREWS: STAINLESS STEEL
9. FRAME: ZINC DIE CAST; NICKEL PLATED
10. O-RING: SILICON; BLUE
11. RUBBER GASKET: TPE, BLACK
12. PCB-SNAPS: COPPER ALLOY; min. 200µm TIN over 80µm NICKEL  
PCB-HOLE: Ø3,1±0,1; PCB THICKNESS 1,6mm
13. SEALING COMPOUND: PUR; BLUE
14. P.C.B. HOLE DRILLINGS and RECOMMENDED PANEL CUT-OUT ON SHEET 2
15. RECOMMENDED TORQUE FOR MOUNTING SCREW  
35N cm (3.1in.LB)/max. 40N cm (3.5 in.LB)
16. CONNECTOR IS PART MARKED: **6STD25P□T99S40X CONEC ABC** (see note 4)

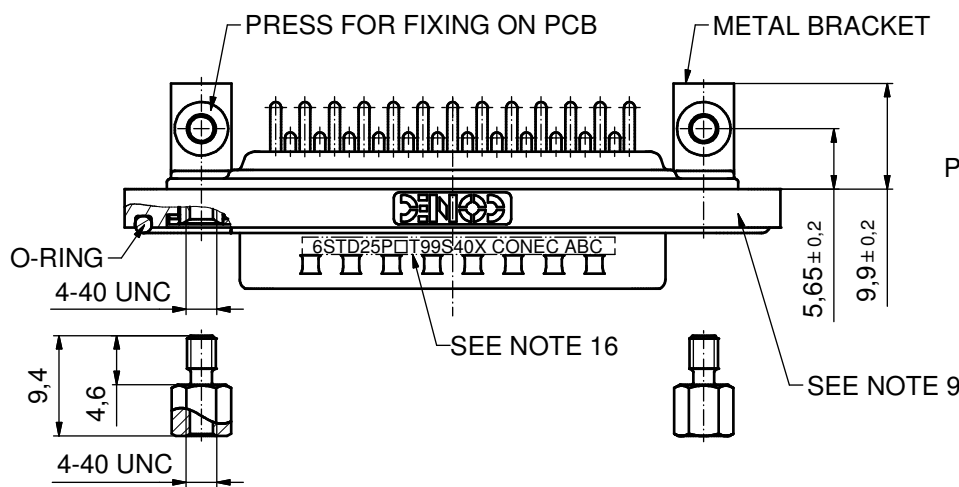
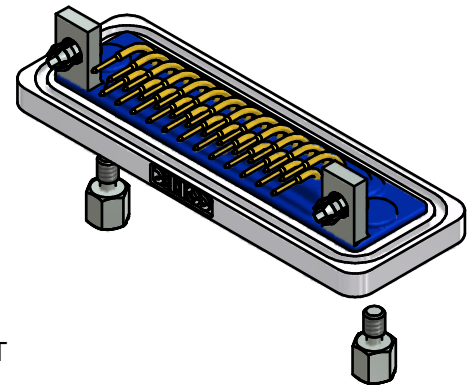
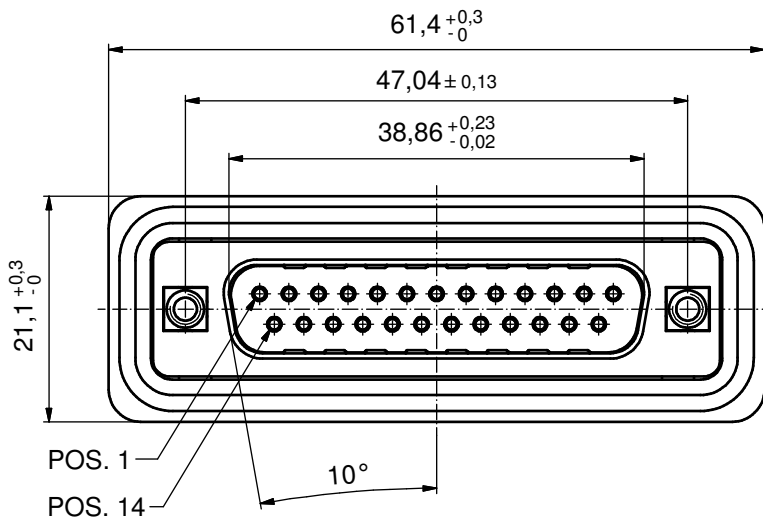
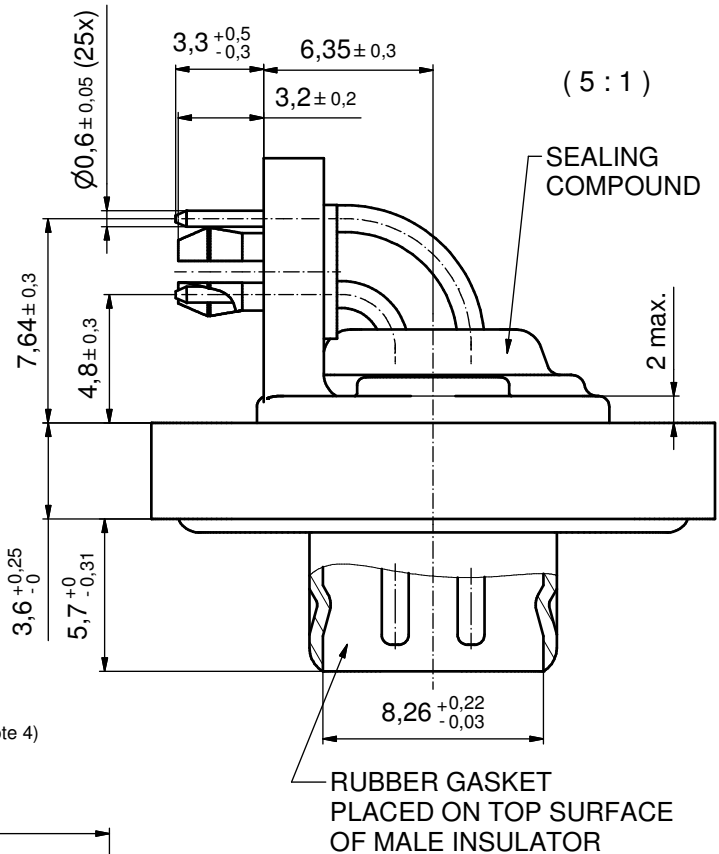

AT ALL TIMES WATER RESISTANT CONNECTORS NOT IN USE SHOULD BE COVERED WITH A CONEC WATER RESISTANT CAP OR WATER TIGHT HOOD.

RoHS compliant

THIS DRAWING MAY NOT BE COPIED OR REPRODUCED IN ANY WAY, AND MAY NOT BE PASSED ON TO A THIRD PARTY WITHOUT WRITTEN PERMISSION. OWNERSHIP AND COPYRIGHT OF CONEC GmbH				tolerance		scale: 2:1 (5:1)	
				dim. in mm		material: SEE NOTES	
DO NOT ALTER CAD DRAWING BY HAND				date	name	title: <b>D-SUB MALE 90°</b> 25pos. SOLDER PIN ANGLED with threaded insert, metal bracket, snap and hex bolt	
				drawn	05.01.16 Henneboel		
appd.	05.01.16 Lehmenkühler	dwg no:					
norm				d-old		18K1A305/18K2A305	
1 x b	A5914	05.01.2016	K.H.	<b>CONEC</b>		15K1A1838	
a	Original					part no: 6STD25P□T99S40X (see note 4)	
rev.	description	date	name			DIN-A3 sh: 1/2	

