

DRAWING MADE IN THIRD ANGLE PROJECTION

THIS DRAWING IS UNPUBLISHED. RELEASED FOR PUBLICATION, 19 .
 © COPYRIGHT 19 BY AMP INCORPORATED. ALL INTERNATIONAL RIGHTS RESERVED.

LOC	DIST	P	F	REVISIONS		DATE	APPD
AF	50			ZONE	LTR	DESCRIPTION	
					A	RELEASE PER FASR, REV PER AF-8005	6/23/92 PF/GY

1 CONTINUOUS STRIP ON REEL.

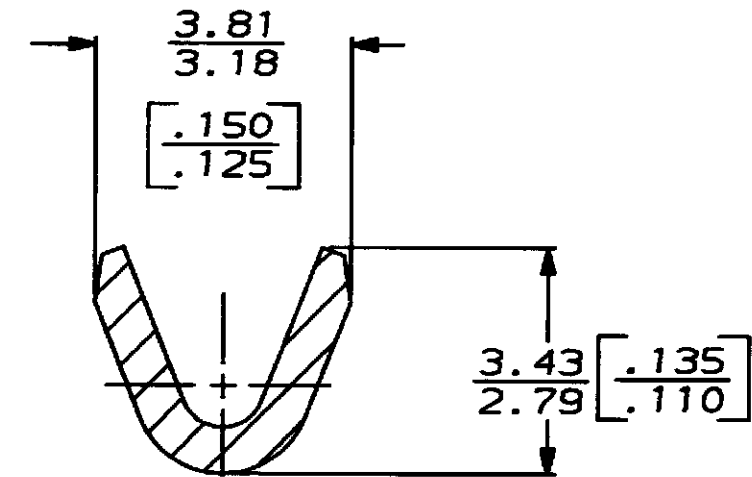
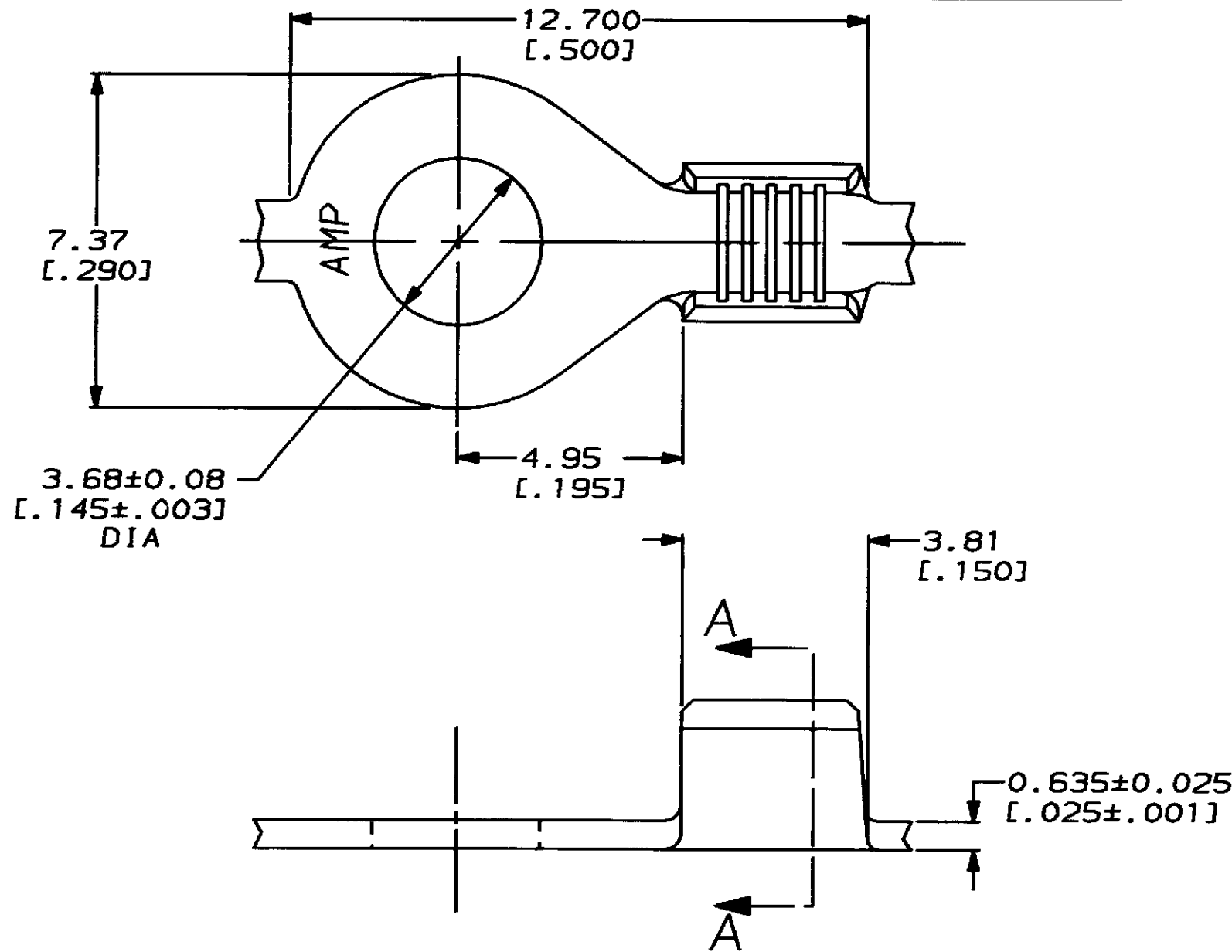

SECTION A-A
SCALE 10:1

F		2.79 [.110]	1.47 [.050]	0.8mm [18]	0.64-1.02mm DIA [22-18] AWG	63649-1
TYPE		WIDTH	HEIGHT	WIRE	MAGNET WIRE RANGE	PART NO
WIRE BARREL CRIMP		±0.051 [E-.002]	1.40 [.055]	0.6mm [20]		
			1.35 [.053]	0.3mm [22]		
DO NOT SCALE PRINT. UNLESS SPECIFIED DIMENSIONS IN mm (INCHES) TOLERANCES ON: 2 PLC DEC ± 0.25 (.010) 3 PLC DEC ± - ANGLES ± -				DR 5/6/92 P FORTNEY		AMP AMP Incorporated Harrisburg, PA 17105-3608
MATERIAL 082 BRASS				CHK 5/6/92 NS FEHER		
FINISH 0.002032 [.000080] MIN TIN PL PER MIL-T-10727				APPD 5/6/92 G YETTER		NAME RING, AMPLIVAR
THIS DRAWING IS A CONTROLLED DOCUMENT FOR AMP INCORPORATED. IT IS SUBJECT TO CHANGE AND THE CONTROLLING ENGINEERING ORGANIZATION SHOULD BE CONTACTED FOR THE LATEST REVISION.				APPD 5/6/92 R MEVILL		SIZE B
				PRODUCT SPEC -		CAGE CODE 00779
				APPLICATION SPEC -		DRAWING NO C-63649
				WEIGHT -		SCALE 8:1
						SHEET 1 OF 1

AMP 1470-15 REV 3-92

23 JUN 1992 10:01:05 AMP17795 <US128A>DEPT2122>DMG2122>U.R&S

CUSTOMER DRAWING