

LOC		DIST		REVISIONS			
REV	BY	DATE	DESCRIPTION	DATE	BY	CHK	APPV
AJ	16						
BL1			REVISED PER ECO-11-005030	11MAR11	RK	HMR	

1. SEE IS 1770
2. BRASS PER QQ-B-626
3. NYLON PER ASTM-D-4066, NATURAL.
4. POLYMETHYLPENTENE GENERAL PURPOSE.
5. .000030 MINIMUM GOLD PER MIL-G-45204.
6. .000100 MINIMUM GOLD PER MIL-G-45204.

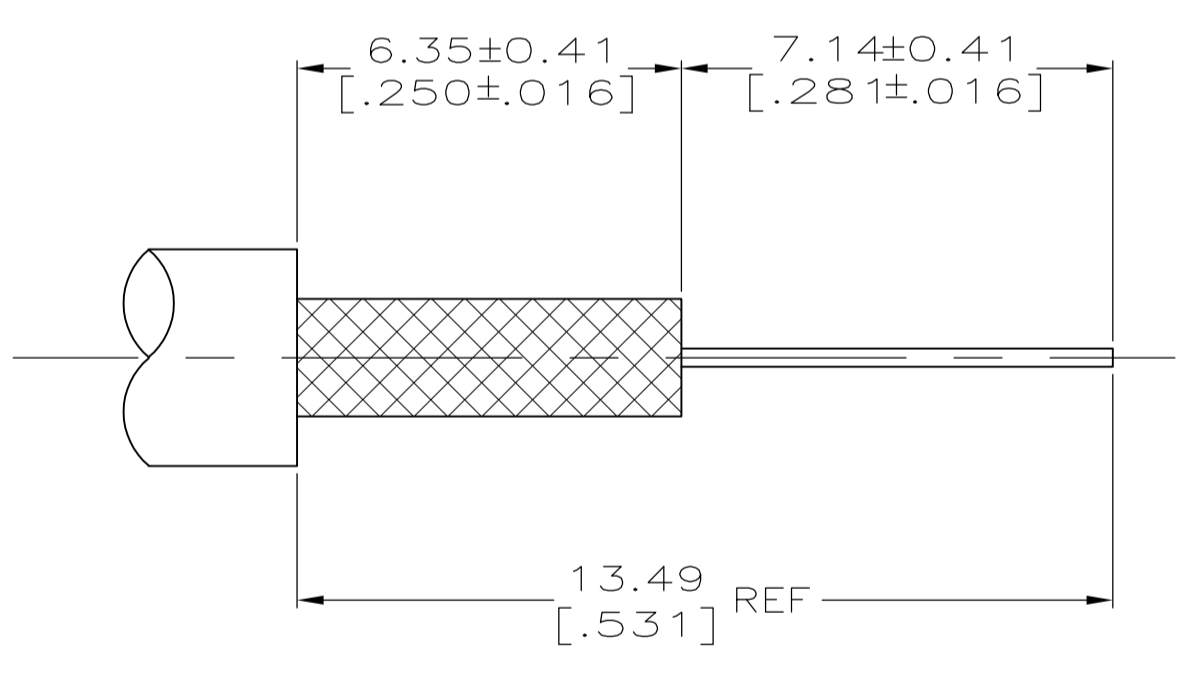
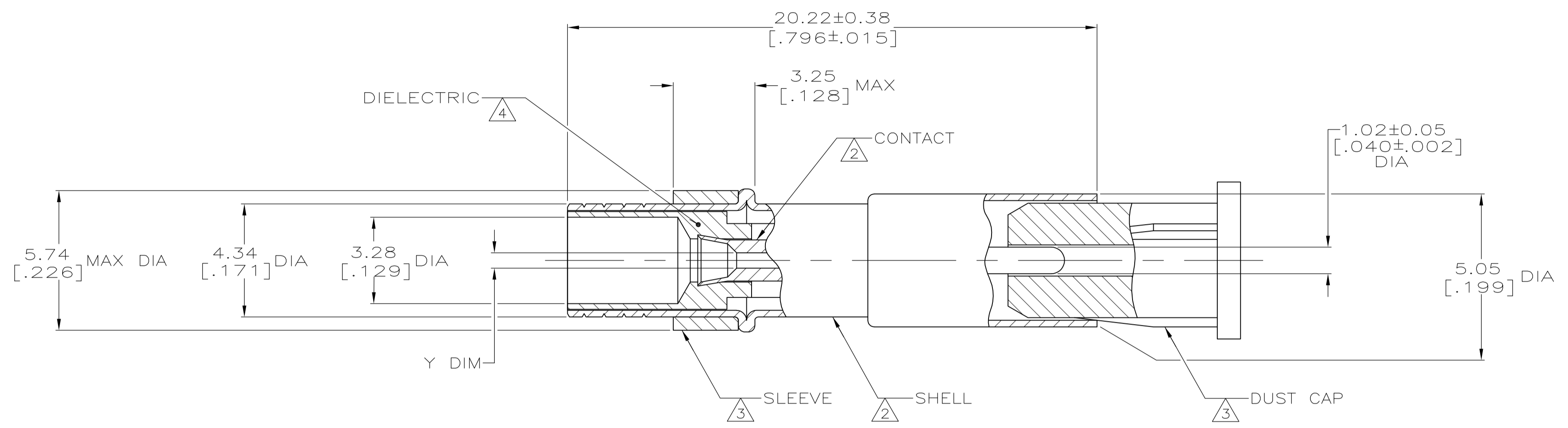

RECOMMENDED STRIP LENGTH

REV	DESCRIPTION	DATE	BY	CHK	APPV
6	OBSOLETE				
5					
4					
3					
2					
1					

CONTACT PLATING	SHELL PLATING	"Y" DIM	PART NUMBER

THIS DRAWING IS A CONTROLLED DOCUMENT.		DWG: WERNER 8-9-94	STE TE Connectivity	
DIMENSIONS: mm [INCHES]		CHK: J. McLEOD 8-9-94	NAME: SOCKET, MINIATURE SERIES	
TOLERANCES UNLESS OTHERWISE SPECIFIED:		APPV: J. McLEOD 8-9-94	PRODUCT SPEC: APPLICATION SPEC	
0. PLC	± -	SIZE: A1 00779 C=201146		
1. PLC	± -	WEIGHT: -		
2. PLC	± 0.20 [.008]	SCALE: 8:1 SHEET 1 OF 1 REV BL1		
3. PLC	± -	CUSTOMER DRAWING		
4. PLC	± -			
ANGLES	± -			
MATERIAL	FINISH			