

Apr.1.2017 Copyright 2017 HIROSE ELECTRIC CO., LTD. All Rights Reserved.

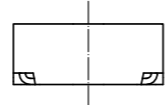

NOTE) 1 . ALL LEAD CO-PLANARITY SHALL BE 0.08mm MAX
 2 CONTACT PLATING SPECIFICATIONS.
 CONTACT AREA : GOLD 0.05 μm MIN
 SMT LEAD : GOLD 0.05 μm MIN
 UNDERPLATING : NICKEL 1 μm MIN
 (SURFACE : SEALING)
 3 REINFORCED METAL FITTINGS LOCK
 SMT LEAD : GOLD 0.05 μm MIN
 UNDERPLATING : NICKEL 1 μm MIN
 (SURFACE : SEALING)
 4 CAV NO. AND HRS MARK MAY BE INDICATED IN APPROX POSITION SHOWN.

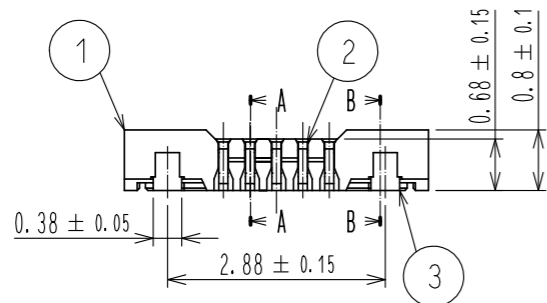
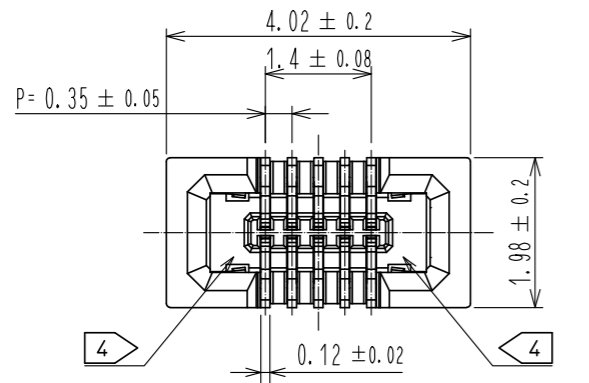
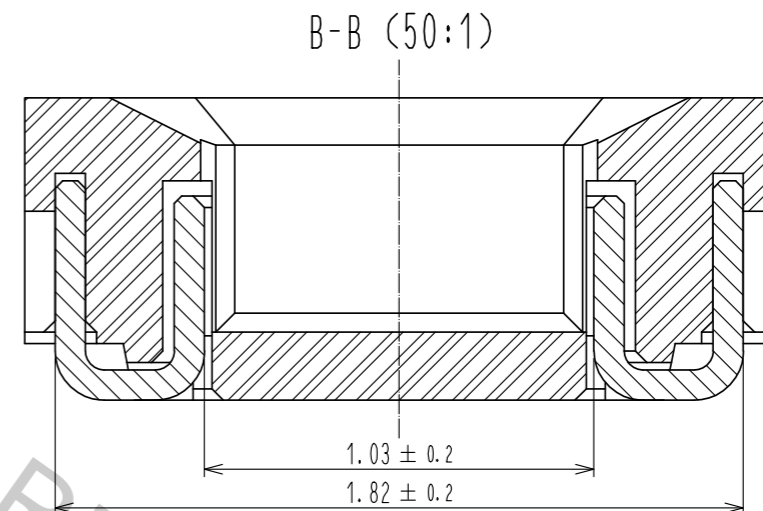
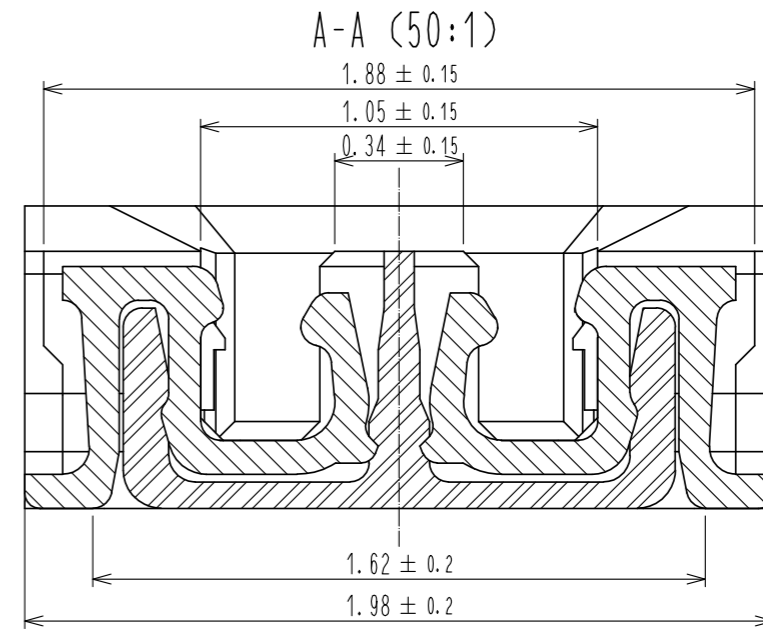

ENGAGEMENT FIGURE (50:1)

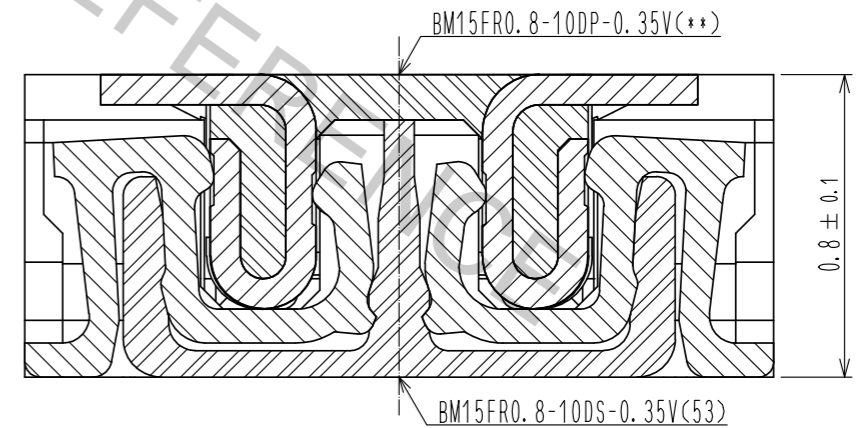

4	PS	CLEAR (ENBOSSED CARRIER TAPE)	7	PS	CLEAR (REINFORCEMENT COLLAR)
3	PHOSPHOR BRONZE	3	6	PS	BLACK (PLASTIC REEL)
2	PHOSPHOR BRONZE	2	5	POLYESTER	CLEAR (COVER TAPE)
1	LCP	UL94 V-0, BLACK			
NO.	MATERIAL	FINISH . REMARKS	NO.	MATERIAL	FINISH . REMARKS

UNITS mm		SCALE 10:1	COUNT 1	DESCRIPTION OF REVISIONS	DESIGNED	CHECKED	DATE
HIROSE ELECTRIC CO., LTD.				APPROVED : MO. ISHIDA 16.01.08 CHECKED : TS. MIYAZAKI 16.01.08 DESIGNED : SH. HOSODA 16.01.07 DRAWN : KR. AJITO 16.01.07	DRAWING NO. EDC-355885-53-01 PART NO. BM15FR0.8-10DS-0.35V(53) CODE NO. CL673-1225-5-53		

◆ RECOMMENDED PCB LAYOUT

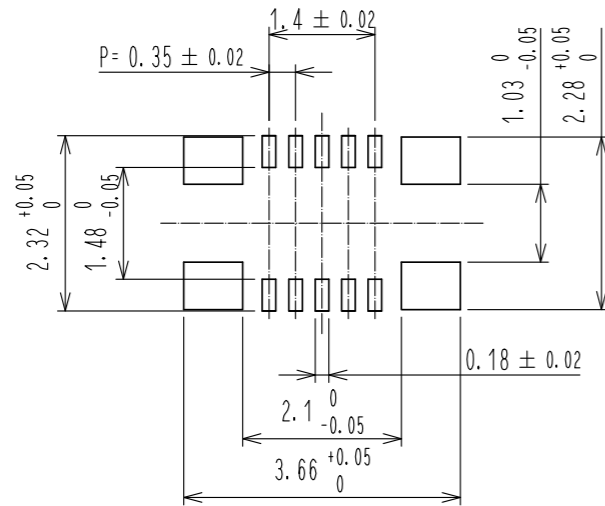

◆ RECOMMENDED METAL MASK DIMENSIONS

METAL MASK THICKNESS : 100 μm

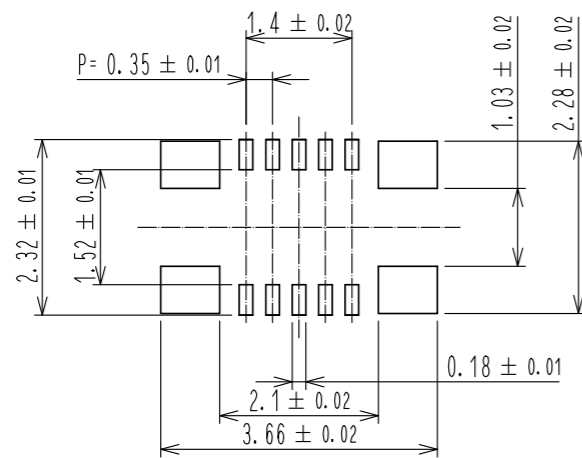

⑤ RECOMMENDED REFLOW TEMPERATURE PROFILE USING LEAD-FREE SOLDER PASTE.

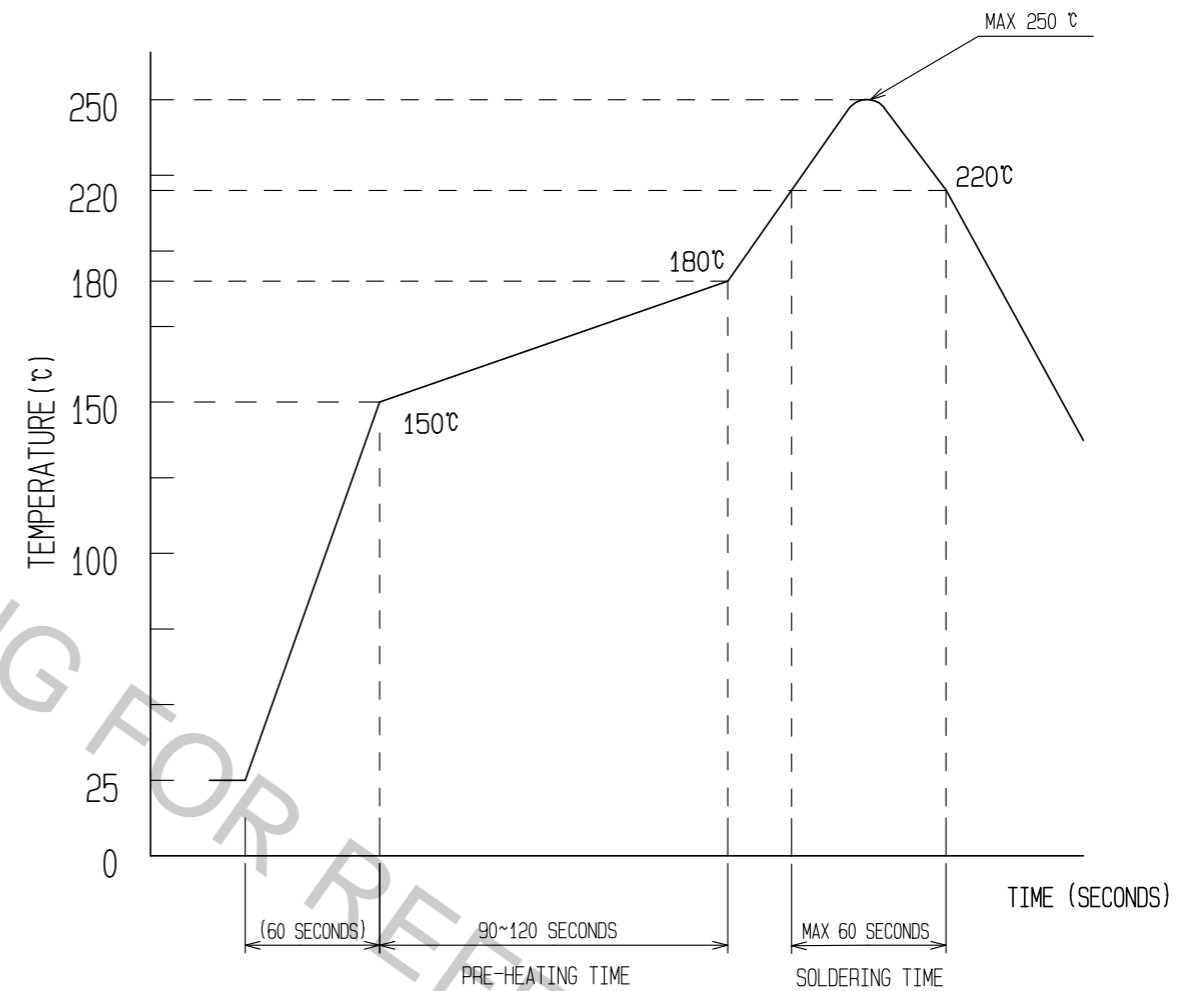

- REFLOW METHOD: IR REFLOW
 NUMBER OF REFLOW CYCLES: 2 CYCLES MAX.
- REFLOW TIME
 DURATION ABOVE 220°C, 60 SEC. MAX.
 (PEAK TEMPERATURE: 250°C MAX)
 - PRE-HEAT TIME
 PRE-HEAT TEMPERATURE(MIN): 150°C
 PRE-HEAT TEMPERATURE(MAX): 180°C
 PRE-HEAT TIME: 90-120 sec.

⑤ THIS TEMPERATURE PROFILE IS PER THE CONDITIONS SHOWN ABOVE. ADDITIONAL FACTORS, SUCH AS SOLDER PASTE TYPE, PCB SIZE AND OTHER MOUNTED COMPONENTS COULD AFFECT THE PROFILE, THEREFORE, A THOROUGH EVALUATION OF MOUNTING CONDITION IS REQUIRED PRIOR TO PRODUCTION. TEMPERATURE IS MEASURED AT CONTACT LEAD.

HRS	DRAWING NO.	EDC-355885-53-01
	PART NO.	BM15FR0.8-10DS-0.35V(53)
	CODE NO.	CL673-1225-5-53

EMBOSED CARRIER TAPE PACKAGING (5:1)

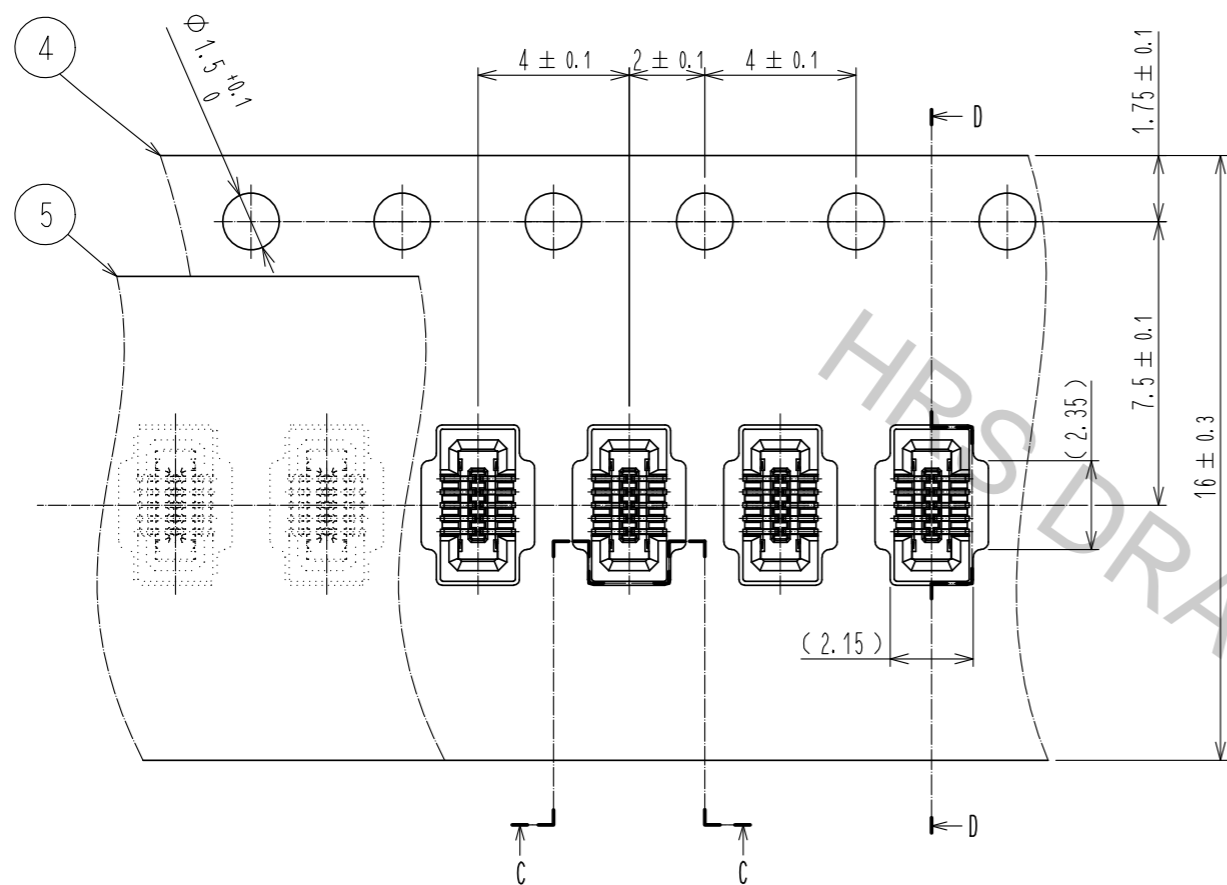

DIRECTION OF UNREELING

C-C (5:1)

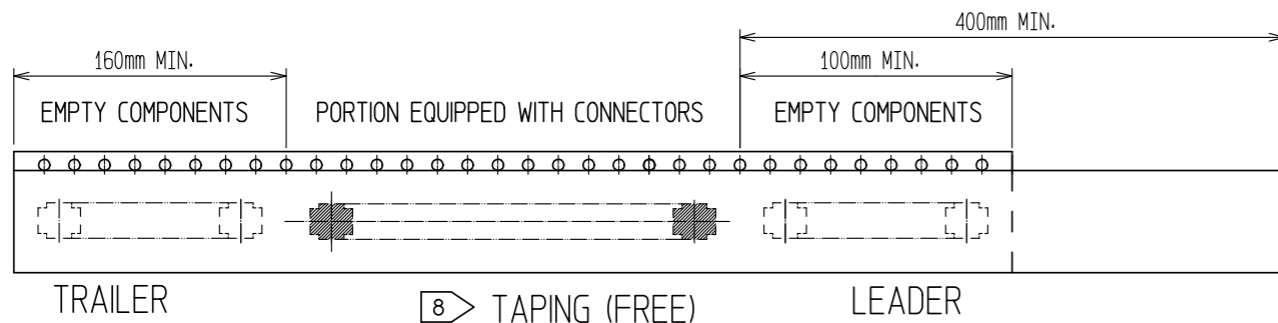
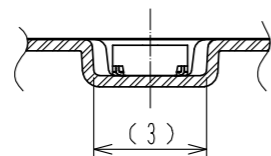

D-D (5:1)

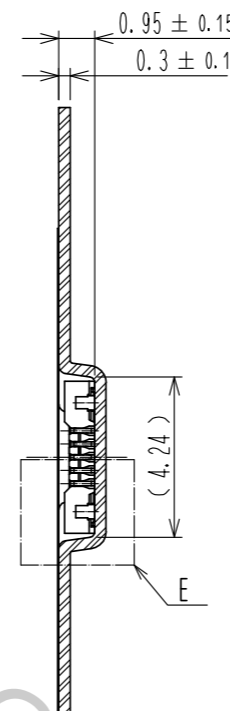

STYLE AND DIMENTION OF REEL (FREE)

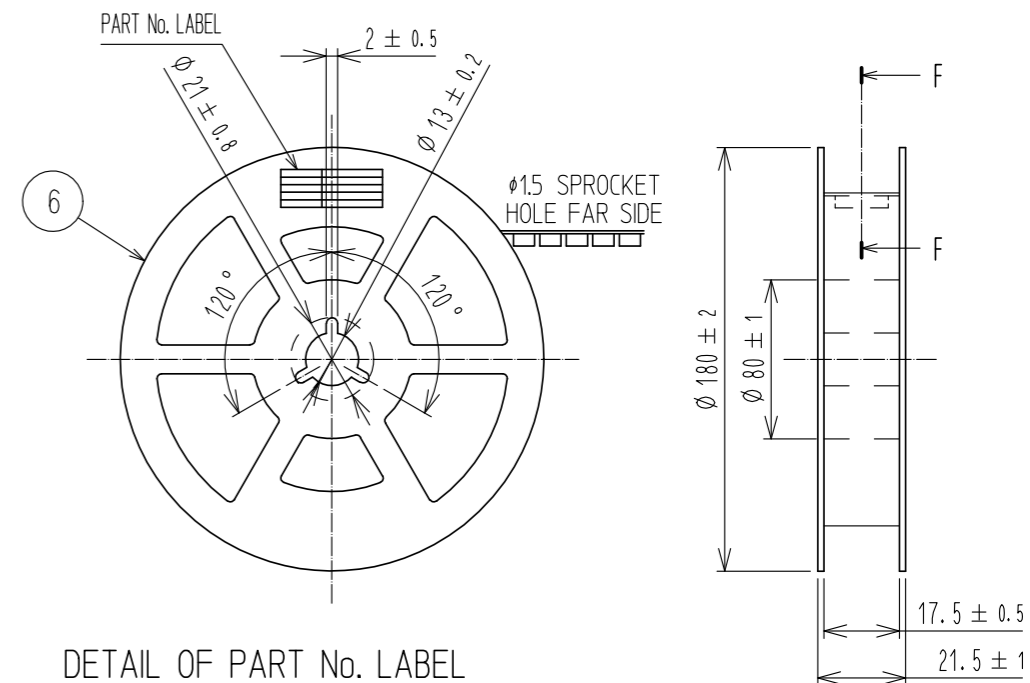

DETAIL OF PART No. LABEL

SUPPLIER	
QUANTITY	
PART No.	
CODE No.	
DATE OF MANUFACTURED	
製造年月日	** ** *
製品コード	CL673-1225-5-53
製品名	BM15FR0.8-10DS-0.35V(53)
数量	1,000
納入者	ヒロセ電機(株)

F-F (FREE)

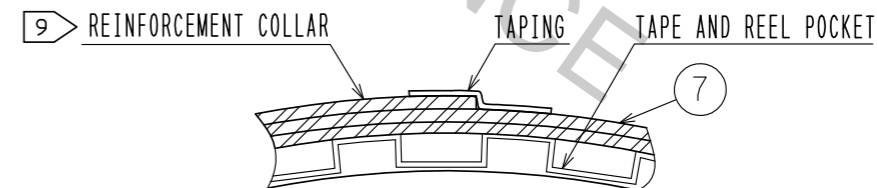

E(10:1)

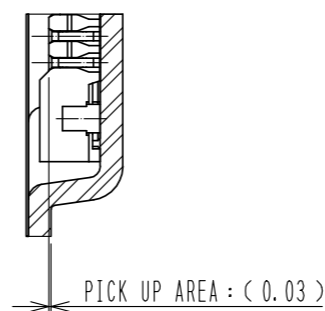

- 6. PER REEL 1000 CONNECTORS.
- 7. THE DIMENSIONS IN PARENTHESES ARE FOR REFERENCE.
- 8 REFER TO JIS C 0806 AND IEC 60286-3
(PACKAGING OF COMPONENTS FOR AUTOMATIC HANDLING)
- 9 AFTER PACKAGING, ROLL 2 METERS OF THE REINFORCEMENT COLLAR TO OUTER CIRCUMFERENCE OF TAPE AND REEL POCKET, AND TAPE DOWN AT THE END THE COLLAR.

HRS	DRAWING NO.	EDC-355885-53-01
	PART NO.	BM15FR0.8-10DS-0.35V(53)
	CODE NO.	CL673-1225-5-53
		\triangle 3/3