

REVISION HISTORY			
REV	DESCRIPTION	DATE	APPROVED
-	REL. DCN 35131	05/07	STW

PRODUCT DATA DRAWING

MATERIAL:

- BODY & COUPLING NUT:** STAINLESS STEEL PER AMS-5640, ALLOY UNS S30300, TYPE 1
- CONTACT & CRIMP RING:** BRASS ASTM-B16, ALLOY UNS C36000, HO2
- LOCK RING:** BERYLLIUM COPPER PER ASTM-B196, ALLOY No. UNS C17300, TD04
- INSULATOR:** PTFE PER ASTM D1710, TYPE I, GRADE 1, CLASS B
- GASKET:** SILICONE RUBBER PER A-A-59588, CLASS 2B
- SHRINK TUBING:** POLYOLEFIN PER MIL-DTL-23053/4-102-0

FINISH:

- CONTACT:** GOLD PER ASTM B488, TYPE II, CODE C, CLASS 1.27 MIN; OVER NICKEL PER AMS-QQ-N-290, CLASS 1, .00005" MIN
- BODY & COUPLING NUT:** PASSIVATED PER AMS 2700, TYPE 2
- CRIMP RING:** NICKEL PER AMS QQ-N-290, CLASS 2 .00005" MIN

PERFORMANCE:

- IMPEDANCE:** 50 OHMS
- DWV:** 750 VRMS
- FREQ. RANGE:** DC-12.4 GHz
- INSUL. RES. :** 5000 MEGOHMS. MIN.
- VSWR:** 1.15+.02(F), 0.5 TO 12.4 GHz, OR APPROXIMATELY 80% OF THE CUTOFF FREQUENCY OF THE CABLE.
- TEMP. RANGE:** -65°C TO +165°C

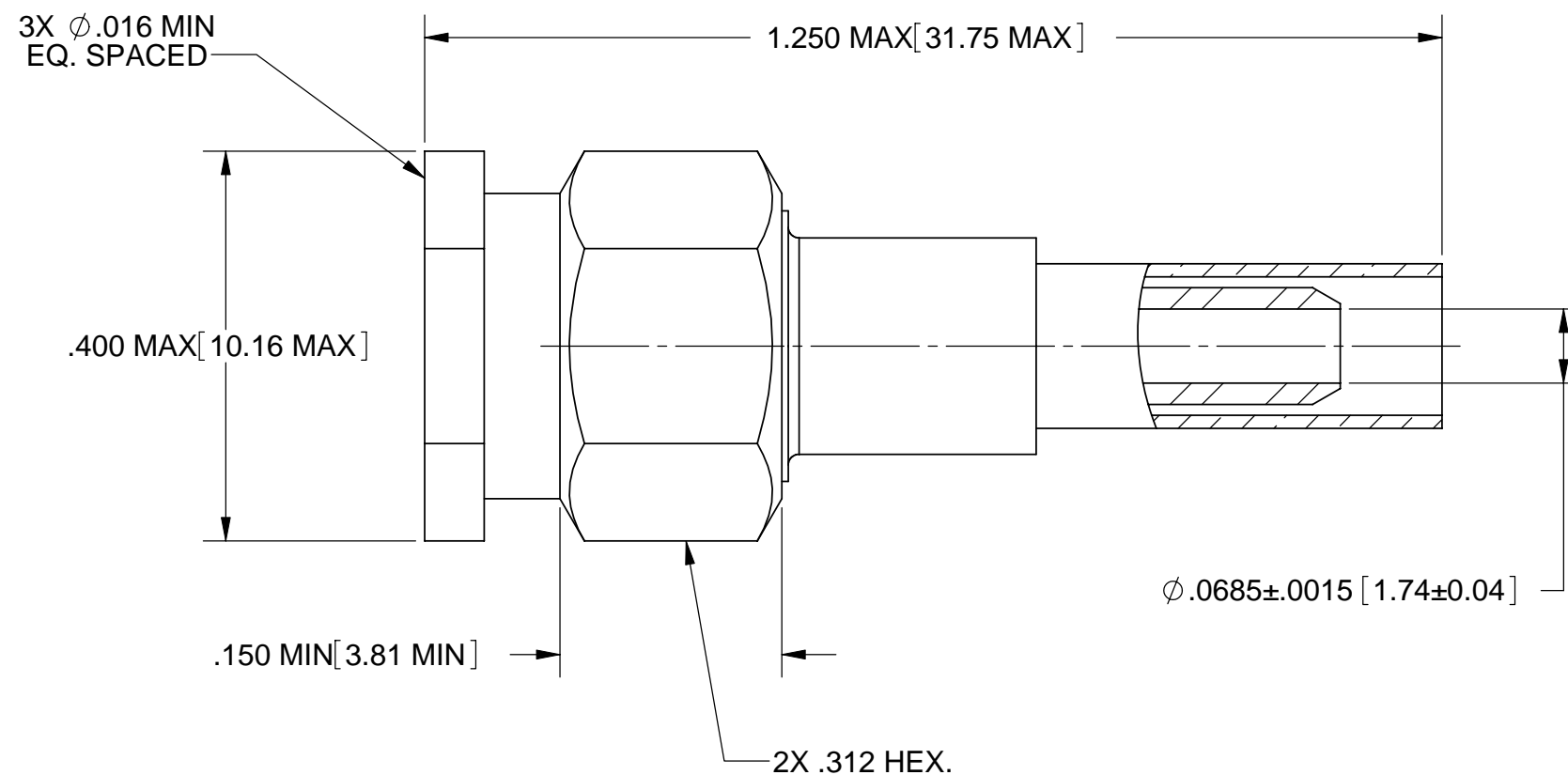

- NOTES:**
- SHRINK TUBING NOT SHOWN.

MATERIAL: SEE NOTES	DIMENSIONS ARE IN INCHES TOLERANCES: FRACTIONAL: ±1/64 ANGULAR: X° ±1'0" X'X' ±15'	UNLESS OTHERWISE SPECIFIED	SV Microwave, Inc. 2400 Centrepark West Drive, Suite 100 West Palm Beach, FL 33409 TITLE: SMA STRAIGHT CRIMP PLUG FOR RG-316 CABLE
FINISH: SEE NOTES	DECIMAL: .X ±.030 .XX ±.010 .XXX ±.005	1) ALL DIMENSIONS ARE IN INCHES (MILLIMETERS) 2) ALL DIMENSIONS ARE AFTER PLATING. 3) BREAK CORNERS & EDGES .005 R. MAX. 4) CHAM. 1ST & LAST THREADS. 5) SURFACE ROUGHNESS 63 MIL-STD-10. 6) DIA.'S ON COMMON CENTERS TO BE CONCENTRIC WITHIN .005 T.I.R. 7) REMOVE ALL BURRS	
SURFACE AREA: N/A	INTERPRET DIMENSIONS AND TOLERANCES PER ASME Y14.5M - 1994	THIRD ANGLE PROJECTION	DWG. NO. M39012/55B3012 SIZE B CAGE CODE 95077
PROPRIETARY THE INFORMATION CONTAINED IN THIS DRAWING IS THE SOLE PROPERTY OF SV MICROWAVE, INC. ANY REPRODUCTION IN PART OR AS A WHOLE WITHOUT THE WRITTEN PERMISSION OF SV MICROWAVE, INC IS PROHIBITED.	DRAWN: ADK 05/21/07 CHECKED: STW 05/22/07 APPROVED: STW 05/22/07	SCALE: 1:0.166667	SHEET 1 OF 1