

MODEL CUB2L - MINIATURE ELECTRONIC 6-DIGIT COUNTER



- INTERNAL LITHIUM BATTERY PROVIDES UP TO 10 YEARS OF UNINTERRUPTED OPERATION
- FIELD CONNECTABLE FOR FRONT PANEL RESET, REMOTE RESET, OR BOTH
- COUNT SPEEDS UP TO 5 KHz (High Speed Input)
- WIDE TEMPERATURE RANGE -30° TO +75°C

DESCRIPTION

The CUB2L counter is powered by an internal lithium battery, which will provide up to 10 years of continuous operation. This counter has a 6-digit LCD display with 0.35" (9.0 mm) high digits.

This counter uses a CMOS LSI counter circuit chip, mounted on a gold-plated substrate and electrically connected by ultrasonic wire-bonding. Internal electrical interface connections use elastomeric contacts to provide a gas-tight, corrosion resistant connection. Using the latest in micro-electronic assembly and manufacturing techniques provides units with the reliability and dependability required for industrial service. The CUB2L is constructed of a rugged die-cast metal case with clear viewing window.

SPECIFICATIONS

1. **DISPLAY:** 6-digit LCD, 0.35" (9.0 mm) high.
2. **POWER SOURCE:** Internal 3.6 V lithium battery to provide up to 10 years of continuous operation. Battery life is dependent upon usage. Count and reset contacts which remain closed for long periods of time will reduce battery life.
3. **HIGH SPEED INPUT:** 5 KHz from 3.0 V to 6.0 V bi-polar output with a 50% duty cycle.
4. **LOW SPEED INPUT:** 50 Hz from switch contact or open collector transistor with a 50% duty cycle.
5. **REMOTE RESET:** 6 msec min. pulse width (*active low*) from 3.0 V to 6.0 V bi-polar output or an open collector transistor or a switch contact to ground.
6. **ENVIRONMENTAL CONDITIONS:**
Operating Temperature Range: -30° to +75°C
Vibration to IEC 68-2-6: Operational 5 to 500 Hz, 5 g.
Shock to IEC 68-2-27: Operational 30 g.
7. **CONSTRUCTION:** Rugged die-cast metal case with clear viewing window. Panel gasket and mounting clips included.
8. **WEIGHT:** 5.1 oz. (145 g)

DIMENSIONS & INSTALLATION

Counters should be mounted in a panel grounded to the machine frame. After cutting opening in panel, slide the panel gasket over the rear of the counter body to the back of the bezel. Then slide counter through the panel cut-out. Install mounting clips on each side of counter body with mounting screws. Make sure the side rails of the clips fit into the recesses in the side of the counter body so that the "Tang Ends" wedge between the panel opening and body as the screws are tightened.

DIMENSIONS: In inches (mm)

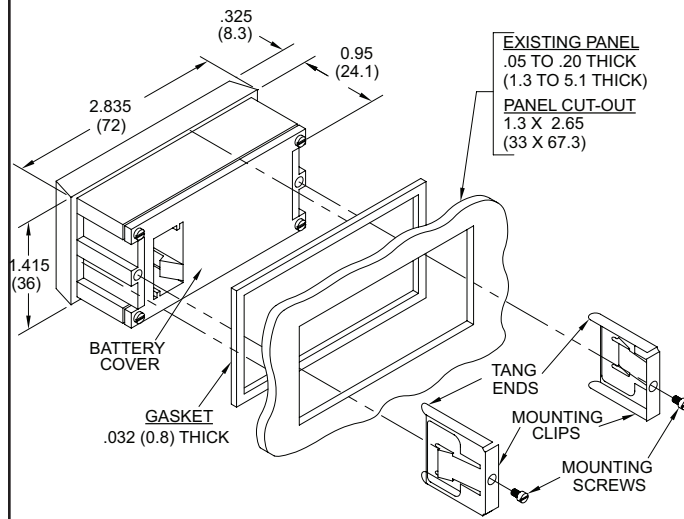

ELECTRICAL CONNECTIONS

There are certain considerations that should be observed when running the count and control signal wires. A length of wire can act like an antenna and the closer it is to a source of electrical noise, the more it becomes susceptible to that noise.

There are a few rules that should be followed when running these wires.

1. Never run count or control signal wires in the same conduit or raceway with AC power lines, conductors that feed motors, solenoids, SCR controls, heaters, etc.
2. Signal wires within enclosures should be routed as far away as possible from contactors, control relays, transformers, and other noisy components.
3. When shielded wire is used, connect the shield to the common of the CUB unit, and leave the other end of the shield disconnected and insulated from machine ground.
4. Mount the CUB2L in a panel that is grounded to the machine frame.

Warning: Lithium battery may explode if incinerated. Signal input voltage should not exceed 6.0 VDC to prevent damage to the counter.

ORDERING INFORMATION

MODEL NO.	DESCRIPTION	PART NUMBERS
CUB2L	CUB2 Counter with Lithium Battery	CUB2L000

APPLICATION FLEXIBILITY VIA RECONNECT OPTIONS

Selection of desired operating modes is easily done by moving terminal leads in the Input Connector Body. The Connector body is polarized to prevent incorrect insertion, and locked in place by the connector latch to avoid accidental disengagement. Connectors are supplied with the 3 leads installed as shown at right. A spare blue lead is supplied in the hardware pack.

Removing Terminal: Insert blade of a small screwdriver into slot of connector body, and gently push in to disengage the locking pawl. Pull terminal out.

Inserting Terminal: When inserting into connector body, make sure the locking pawl is toward the slot in the body. Push terminal in until the locking pawl snaps into slot.

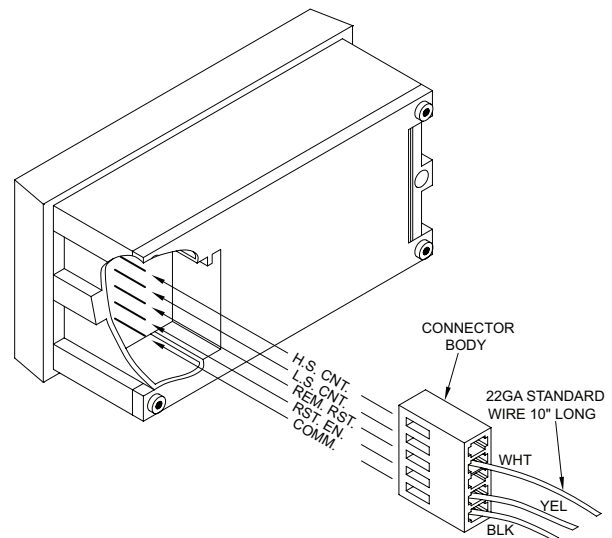
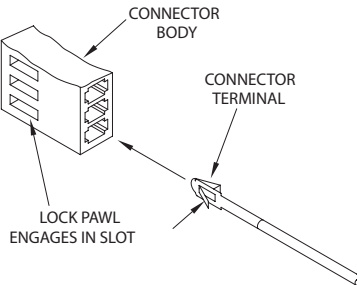

LOW SPEED COUNT INPUT, 50 Hz MAX. [For 250 Hz see note in text]

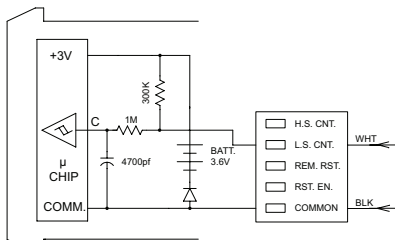

Pulling the "L.S. CNT." Input to Common with a mechanical or solid-state switch increments the counter. The low pass filter (1meg resistor and 4700 pf cap) used with a Schmidt trigger circuit debounces mechanical switch signals. The switch load is 14 μ A (max. voltage drop 0.5 V) when ON. OFF-state leakage current must be less than 2 μ A.

Reed switches, mercury wetted contacts, snap action limit switches, and

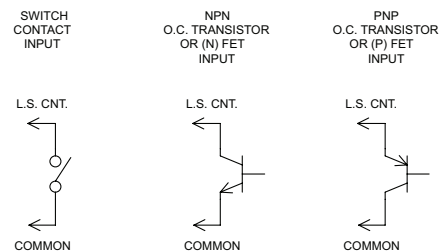

silver alloy relay contacts with wiping action are usually satisfactory for generating count input signals. Motor starter contacts, tungsten contacts, and brush-type contacts should **NOT** be used.

Note: By parallel connecting both "H.S. CNT." and "L.S. CNT." inputs, count speed can be increased to 250 Hz if de-bounce is not needed.

HIGH SPEED COUNT INPUT, 5 KHz MAX.

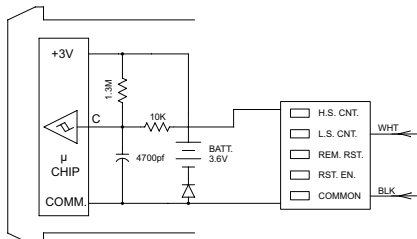

Moving the white wire to the "H.S. CNT." Input allows the CUB Counter to operate at speeds up to 5 KHz when driven by bi-polar outputs or external circuits having an output impedance of 3.3 K Ω or less. Input drive voltage must be limited to 6.0 V maximum to avoid damage to the counter. Outputs higher than 6.0 V can be used with an external voltage divider, as shown.

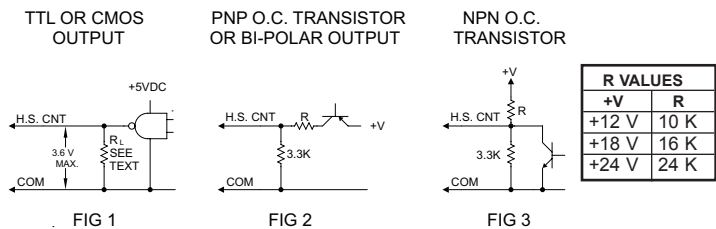

INPUT PULSE EXCURSION LIMITS

$$V_{IN} (\text{High}) = +2.7 \text{ V min.}; +6.0 \text{ V max.}$$

$$V_{IL} (\text{Low}) = +0.5 \text{ V max.}$$

RESET OPTIONS

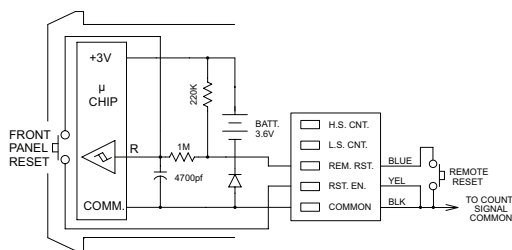

Connecting the "RST. EN." (Reset Enable) Input to Common activates the front panel Reset button. When the front panel Reset button is to be deactivated, remove the yellow wire from the "RST. EN." Input.

When Remote Reset is required, the blue wire in the hardware pack is inserted in the "REM. RST." Input. Pulling this input low causes the counter to reset. The "REM. RST." can be pulled low by either a mechanical switch or solid-state transistor switch. Switch load and leakage are the same as for "L.S. CNT." Input above.

Note: The RC protection circuit on the "REM. RST." Input causes a delay of approximately 6 msec in Reset response.