

## Power Booster Evaluation Kit

### APPLICABLE PARTS (SOLD SEPARATELY)

- PB51

### INTRODUCTION

This easy-to-use kit provides a platform for the evaluation of the PB51 high voltage power boosters. The PB51 is designed most commonly in combination with a small signal, general purpose op amp. However, they can also be used without a driver amplifier. This kit can be used to analyze a multitude of standard or proprietary circuit configurations.

**CAUTION**

Use the supplied thermal washers or thermal grease between the power amplifier and the heat sink.

Figure 1: PCB

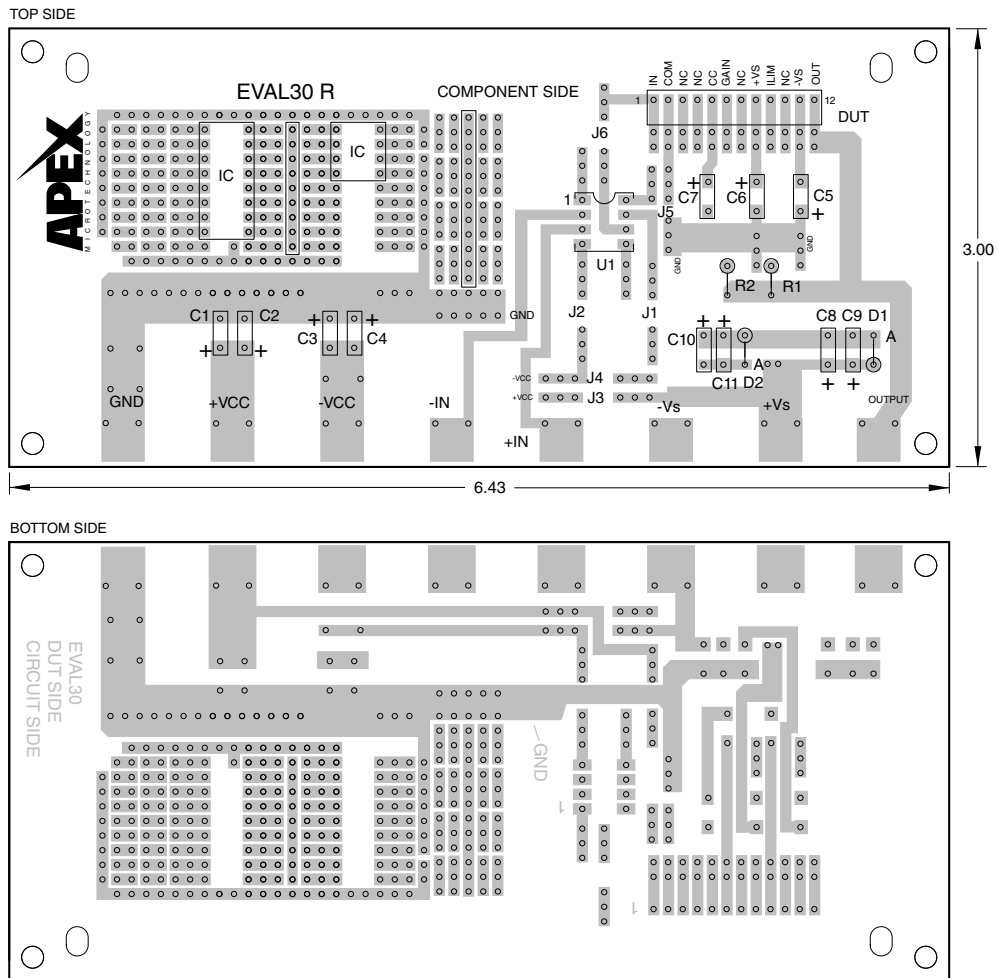
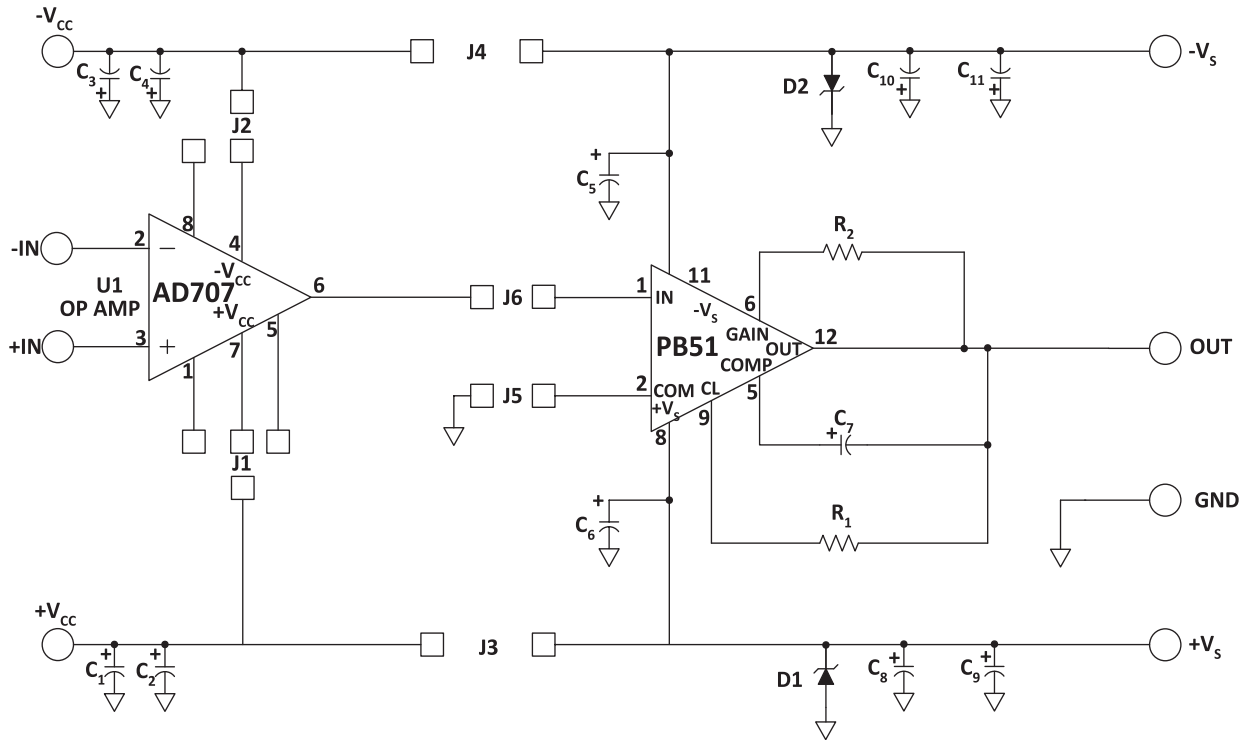

Figure 2: EK Schematic



**PARTS LIST**

Reference	Manufacturer Part #	Description	QTY
	HS20	Heatsink	1
	EVAL30	PC Board	1
	MS06	Mating Socket	1
	TW07	Thermal Washer	1 Package

**BEFORE YOU GET STARTED**

- All Apex Microtechnology amplifiers should be handled using proper ESD precautions.
- Always use the heat sink and thermal washers included in this kit.
- Always use adequate power supply bypassing.
- Do not change connections while the circuit is powered.
- Initially set all power supplies to the minimum operating levels allowed in the device data sheet.
- Check for oscillations.

**ASSEMBLY**

1. On the silk screen side of the evaluation board, insert and solder the MS06 mating socket in DUT holes 1-12. Be sure each one is fully seated.
2. Solder components for your circuit. Be sure to include proper bypassing, required compensation components and current limit resistors. See the op amp data sheet for help in selecting these components.
3. Place the TW07 thermal washer on the heat sink over the mounting hole for the DUT. Place a #6 screw through the mounting hole and thread a #6 nut onto the screw at the back of the heat sink. Do not tighten. Note that there are two sets of mounting holes on the HS20. Holes on one edge allow room between the DUT and evaluation board for the MS06 socket. The holes on the other edge are for direct through hole mounting of the DUT to the evaluation board. It is recommended that you use the MS06.
4. Mount the DUT to the HS20 by sliding under the head of the #6 screw and on top of the thermal washer. Tighten the nut to the specified 8 to 10 in-lbs. (0.9 to 0.13 N\*m) do not over torque.
5. Install leads of the DUT into the MS06 on the evaluation board. Use #6 self-tapping screws to secure the evaluation board to the HS20 heatsink as shown in the assembly diagram (Figure 3).

**Figure 3: Assembly**

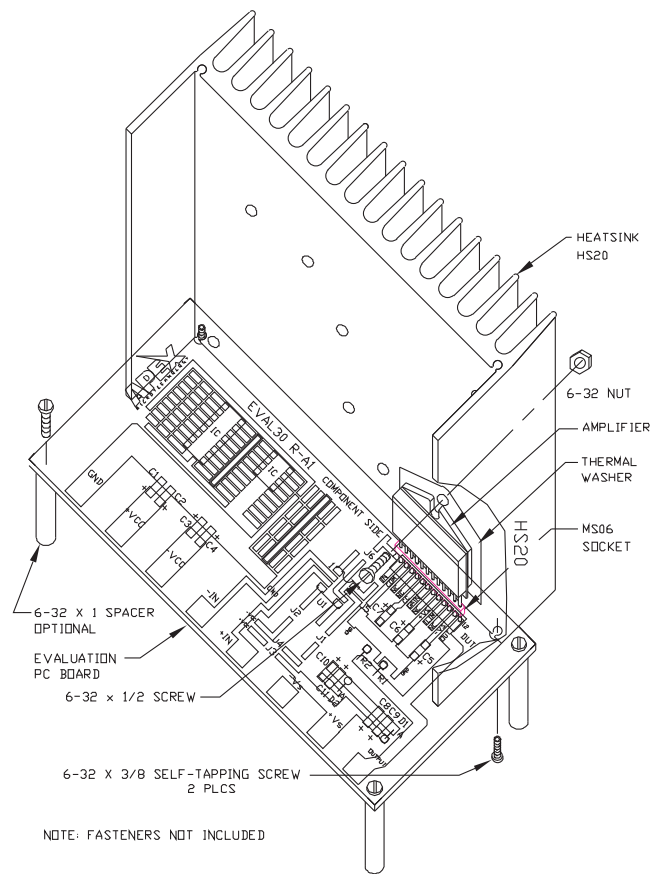

---

## **NEED TECHNICAL HELP? CONTACT APEX SUPPORT!**

For all Apex Microtechnology product questions and inquiries, call toll free 800-546-2739 in North America. For inquiries via email, please contact [apex.support@apexanalog.com](mailto:apex.support@apexanalog.com). International customers can also request support by contacting their local Apex Microtechnology Sales Representative. To find the one nearest to you, go to [www.apexanalog.com](http://www.apexanalog.com)

---

### IMPORTANT NOTICE

Apex Microtechnology, Inc. has made every effort to insure the accuracy of the content contained in this document. However, the information is subject to change without notice and is provided "AS IS" without warranty of any kind (expressed or implied). Apex Microtechnology reserves the right to make changes without further notice to any specifications or products mentioned herein to improve reliability. This document is the property of Apex Microtechnology and by furnishing this information, Apex Microtechnology grants no license, expressed or implied under any patents, mask work rights, copyrights, trademarks, trade secrets or other intellectual property rights. Apex Microtechnology owns the copyrights associated with the information contained herein and gives consent for copies to be made of the information only for use within your organization with respect to Apex Microtechnology integrated circuits or other products of Apex Microtechnology. This consent does not extend to other copying such as copying for general distribution, advertising or promotional purposes, or for creating any work for resale.

**APEX MICROTECHNOLOGY PRODUCTS ARE NOT DESIGNED, AUTHORIZED OR WARRANTED TO BE SUITABLE FOR USE IN PRODUCTS USED FOR LIFE SUPPORT, AUTOMOTIVE SAFETY, SECURITY DEVICES, OR OTHER CRITICAL APPLICATIONS. PRODUCTS IN SUCH APPLICATIONS ARE UNDERSTOOD TO BE FULLY AT THE CUSTOMER OR THE CUSTOMER'S RISK.**

Apex Microtechnology, Apex and Apex Precision Power are trademarks of Apex Microtechnology, Inc. All other corporate names noted herein may be trademarks of their respective holders.