

② STRIPPING DIMENSIONS

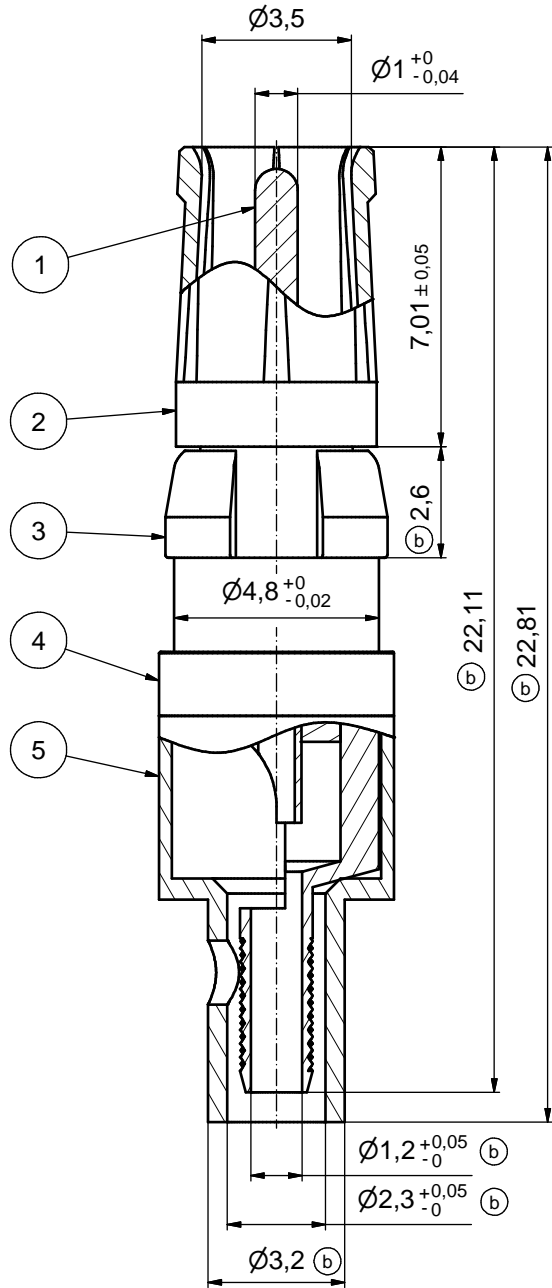
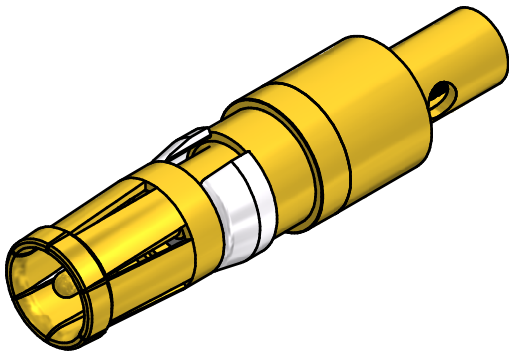
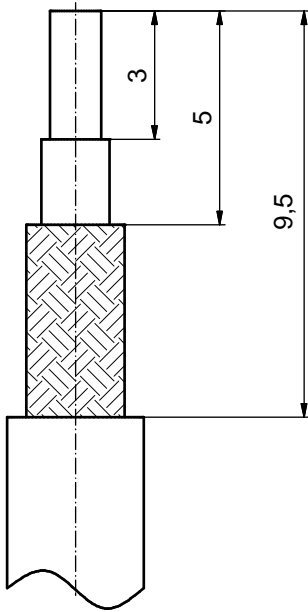

② ASSEMBLY TOOLING:

1. CENTER CONTACT:  
SOLDERED
2. OUTER CONDUCTOR:  
SOLDERED OR CRIMPED  
USE CRIMP TOOL: 360X10519X  
WITH TOOL INSERT: 360X11019X  
INSERT CAVITY C: HEX 2.67/.105

Part no.	Finish Pos.1	Finish Pos.2	Finish Pos.3	Finish Pos. 4/5
132J20019X	min. 50µin HARD GOLD over min. 50µin NICKEL	min. 30µin HARD GOLD over min. 50µin NICKEL	NICKEL PLATED	GOLD FLASH over NICKEL
132A20019X	GOLD FLASH over NICKEL	GOLD FLASH over NICKEL	NICKEL PLATED	GOLD FLASH over NICKEL

Directive 2002/95/EC RoHS compliant

THIS DRAWING MAY NOT BE COPIED OR REPRODUCED IN ANY WAY, AND MAY NOT BE PASSED ON TO A THIRD PARTY WITHOUT WRITTEN PERMISSION. OWNERSHIP AND COPYRIGHT OF CONEC GmbH DO NOT ALTER CAD DRAWING BY HAND	tolerance ISO 2768-c		dim. in mm		scale: 8:1
	date		name		material: COPPER ALLOY (Pos. 1 - 5)
	drawn	10.02.06	Lehmenkühler		title: COAXIAL CONTACT SOCKET 50 OHM center contact solder, outer contact solder/crimp for cable RG 178 B/U, 196 A/U, 404/U
	appd.	10.02.06	Mickenbecker		
	norm				
d-old				dwg no: 13K2IR3A	
9 x b	Ä5173	17.04.14	HS	DIN-A3	
a	Original			sh: 1	
rev.	description	date	name	part no: see table	

