

DWG. NO. SD-1854*

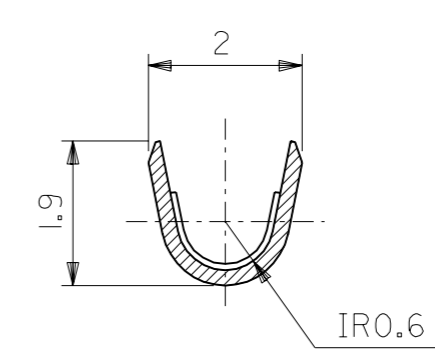

SECT. A-A
(SCALE 10 : 1)

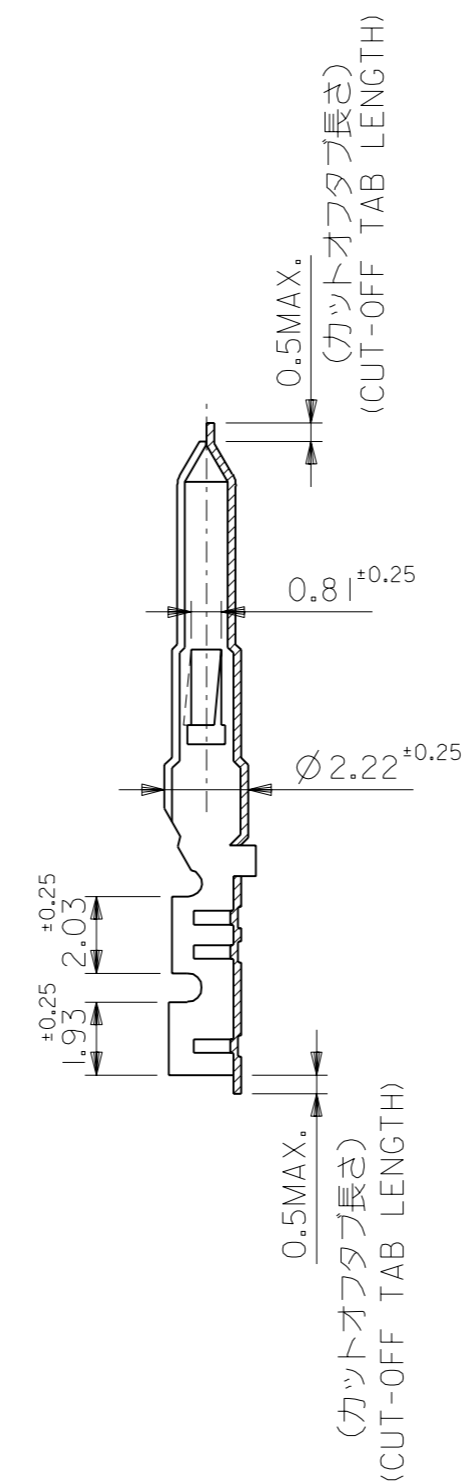
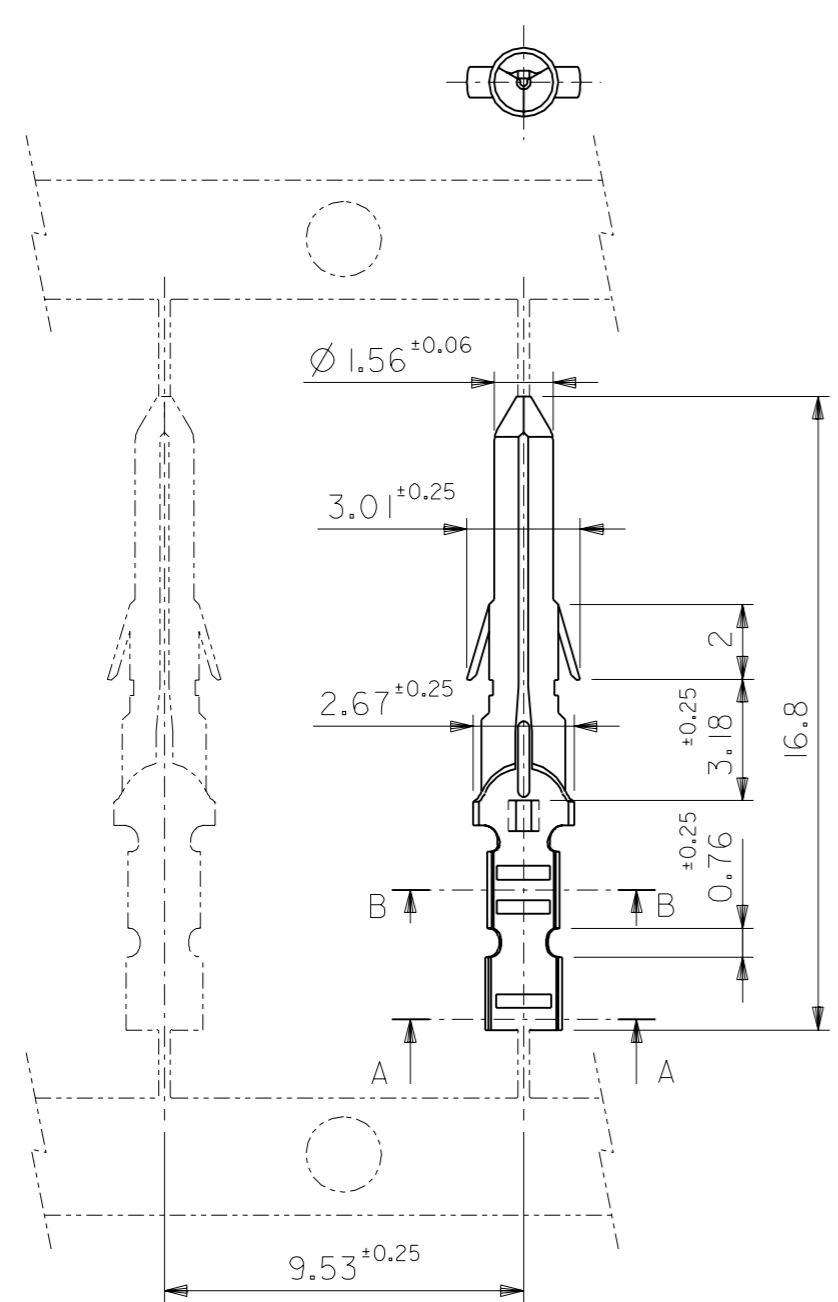
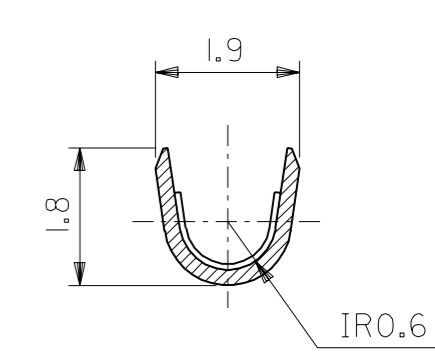

SECT. B-B
(SCALE 10 : 1)

注記 NOTES:
1. 一般公差 : ±0.4
GENERAL TOLERANCES: ±0.4

ニッケル (2 μm MIN.) 下地 金 (0.35 μm MIN.) GOLD (0.35 μm MIN.) OVER NICKEL (2 μm MIN.)	39-00-0337	1854GL	バラ端子 LOOSE
銅 (0.5 μm MIN.) 下地 錫 (0.9 μm MIN.) TIN (0.9 μm MIN.) OVER COPPER (0.5 μm MIN.)	39-00-0336	1854G	連鎖状端子 CHAIN
メッキ PLATING	EDP.NO.	ENG.NO.	形状 FORM

材料 MATERIAL 黄銅 BRASS 0.2 t	MOLEX-JAPAN CO.,LTD. 日本モレックス株式会社	
仕上げ FINISH	REVISE ONLY ON CAD SYSTEM	
適用電線範囲 WIRE RANGE AWG#22-#28	TITLE 名称 .062 DIA. CRIMP MALE TERMINAL	
被覆外径 INS. RANGE φ 1.1~1.5	DWG. NO. SD-1854*	REV K
DRAWN BY '93/07/09 H.HASEGAWA	CHK'D BY '93/07/09 H.HIRAMOTO	
APP'D BY '93/07/09 M.FUKUSHIMA	尺度 SCALE 5 : 1	
角度 ANGLE ±30	記号 LTR	変更内容 REVISION RECORD
30 以上 OVER ±0.3	K	REDRAWN (J30695) 再作図
10 以上 30 未満 OVER UNDER ±0.25	DR. H.H	日付 DATE '93/07/09
10 未満 UNDER ±0.2	CHK. H.H	
一般公差 GENERAL TOLERANCES		